

# ERV

VALVTECHNOLOGIES

## Electronic Relief Valve ANSI 150-4500



The Valvtechnologies Electronic Relief Valve (ERV™) is the answer to the need for a zero-leakage, pilot-operated relief valve. The ERV package combines Valvtechnologies' zero-leakage isolation valve with electronic controls to monitor and regulate system pressure. Whether in a capacity-relieving function requiring the ASME V-stamp, or simply in an overpressure protection application, the Valvtechnologies ERV™ provides reliable protection for standard safety valves in many industries. Valvtechnologies can also provide an integral isolation valve, eliminating the need for costly field welding.

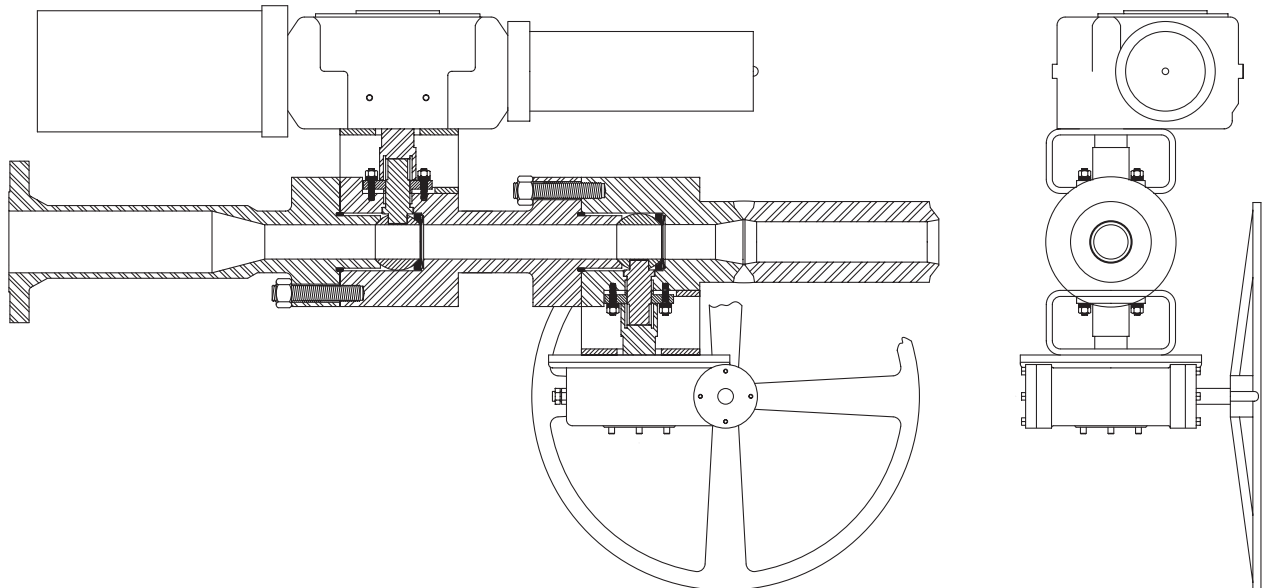

Integral Seat, Four-Year Zero Leakage Guarantee

## Valvtechnologies' Electronic Relief Valves

- Protect safety valves on boilers
- Maintain balance of boiler operations at peak loads
- Maintain uniform line pressures
- Balance boiler operations during off peak loading (sliding pressure controls)

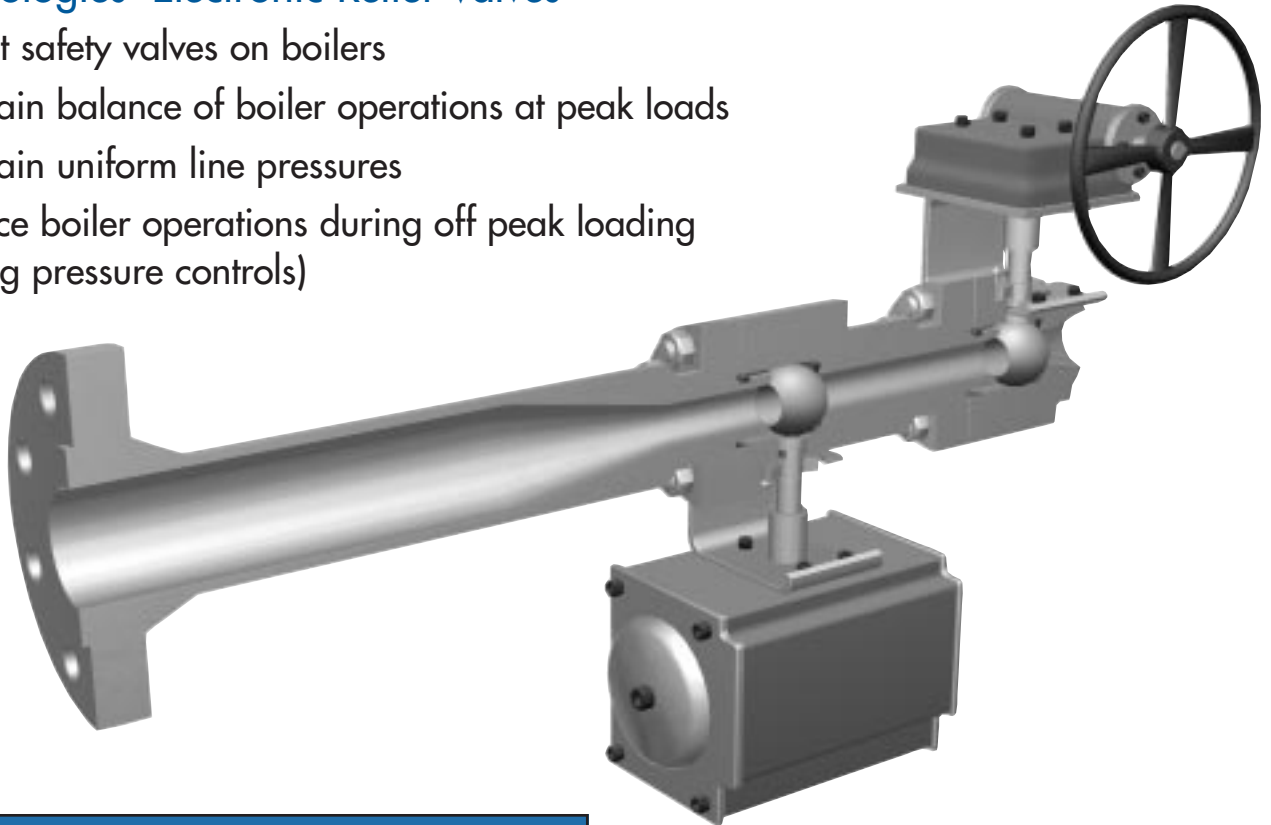

### FEATURES

- ZERO leakage guarantee
- Repeatable tight shut-off
- Accurate to 1/10% of 1 psi
- High precision reliability
- Low maintenance requirements
- Accurate blow downs = major cost savings
- Seat out of flow path when open
- Easily adapted to existing controls
- Various standard control packages
- Integral isolation valves available

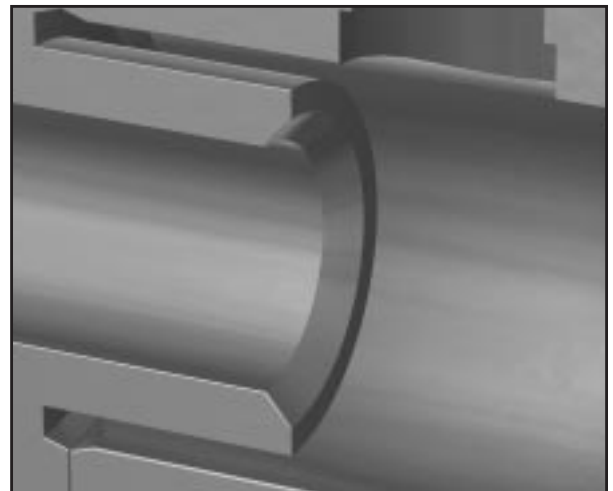

*Integral Seat Detail*

**Integral Seat, Four-Year Zero Leakage Guarantee**

The patented Valvtechnologies' Electronic Relief Valve (ERV) is designed to exhaust to the atmosphere or into a closed system (superheater bypass) and provide total flexibility with both manual and automatic pressure relief of a pressurized system. Seating faces are protected with a chrome-carbide hardcoating with a Rockwell C of approximately 70. Over-pressurization protection is readily controlled either automatically or manually from the control room or the local control station. The ERV is available with complete controls or can utilize existing controls.

PARTS LIST			
ITEM	DESCRIPTION	MATERIAL	QTY.
1	BALL	A10/RAM31	1*
2	UPSTREAM SEAT	A182F22/HF	1*
3	BELLVILLE SPRING	INC 718	1*
4	STEM	A638 Gr. 660/HF	1
5	GLAND	A182F22/HF	1
6	GLAND LOAD SPRING	304 SS	16
7	GLAND NUT	A194 Gr. B8M	4
8	GLAND STUD	A193 Gr. B8M	4
9	END CAP	A182F22/RAM31	1*
10	BODY	A182F22	1
11	BODY GASKET	17-4/P24	1*
12	GLAND PACKING	GRAFOIL/316 S.S.	3*
13	MOUNTING PLATE	1018	1
14	DRIVE SLEEVE	4130	1
15	BODY STUD	A193 Gr. B8M	8
16	BODY NUT	A194 Gr. B8M	8
17	KEY	1018	2
18	PRESSURE SYPHON	A335 P22	1
19	ERV VLV ACTUATOR	HI SPEED ELECTRIC ACTUATOR	1
20	PRESSURE TRANSDUCER	WIKA MODEL# 891.23.510	1
21	COOLING TOWER	WIKA MODEL# 910.24	1
22	DIAPHRAGM	WIKA MODEL# 990.14	1

\* Recommended Spare Parts

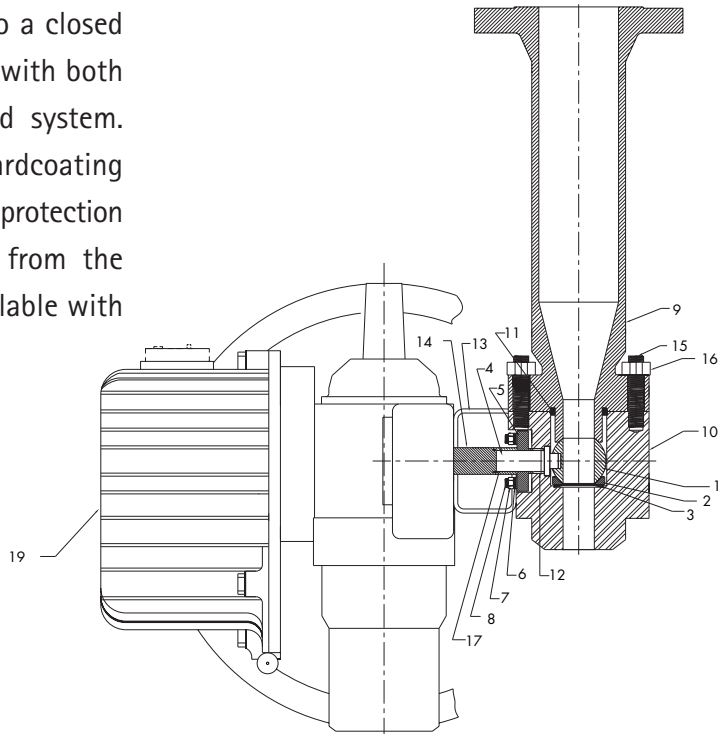

ERV CONTROL BOX

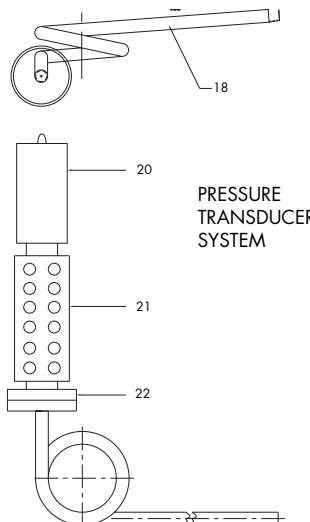
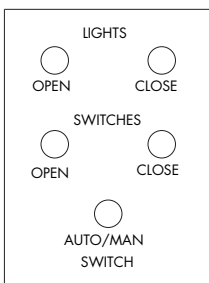

PRESSURE TRANSDUCER SYSTEM

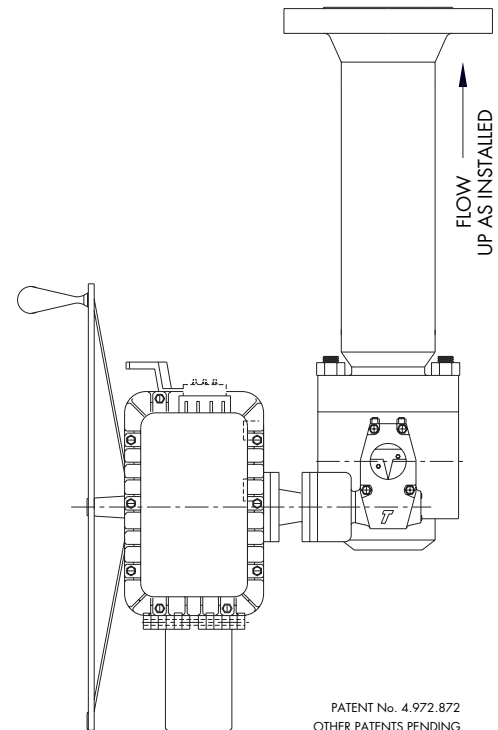

PATENT No. 4.972.872  
OTHER PATENTS PENDING

Integral Seat, Four-Year Zero Leakage Guarantee

## "E" SERIES

**Set Points** – The set points of the "E" series ERV are  $\pm 1/10\%$  uncalibrated. This accuracy results in less steam loss during a blow and better protection of the drum and superheat conventional safety valves.

**Safety** – The take off point for the signal will typically be from the drum or superheater. This live steam point must then be cooled to prevent overheating of the pressure transmitter. To ensure safe maintenance and operations we have designed a system which consists of a coiled P22 piped siphon which is then welded to a Monel diaphragm seal. The outlet of the Monel diaphragm seal is then connected to the miniature cooling tower and the piezoresistive transmitter. As the diaphragm seal is a pressure boundary the transmitter may be removed from the deal without breaking into the pressure boundary.

**Diffuser Outlet** – The diffuser outlet minimizes noise and maximizes flow. The face to face dimensions of the "E Series" is designed with a diffuser outlet and will also be the same design as the conventional straight through solenoid operated relief valves being replaced.

**Controls** – The standard control unit in addition to lights, push buttons and selector switch will also have a programmable controller to allow easy adjustments of blow-down and the set points include a local pressure indication display.

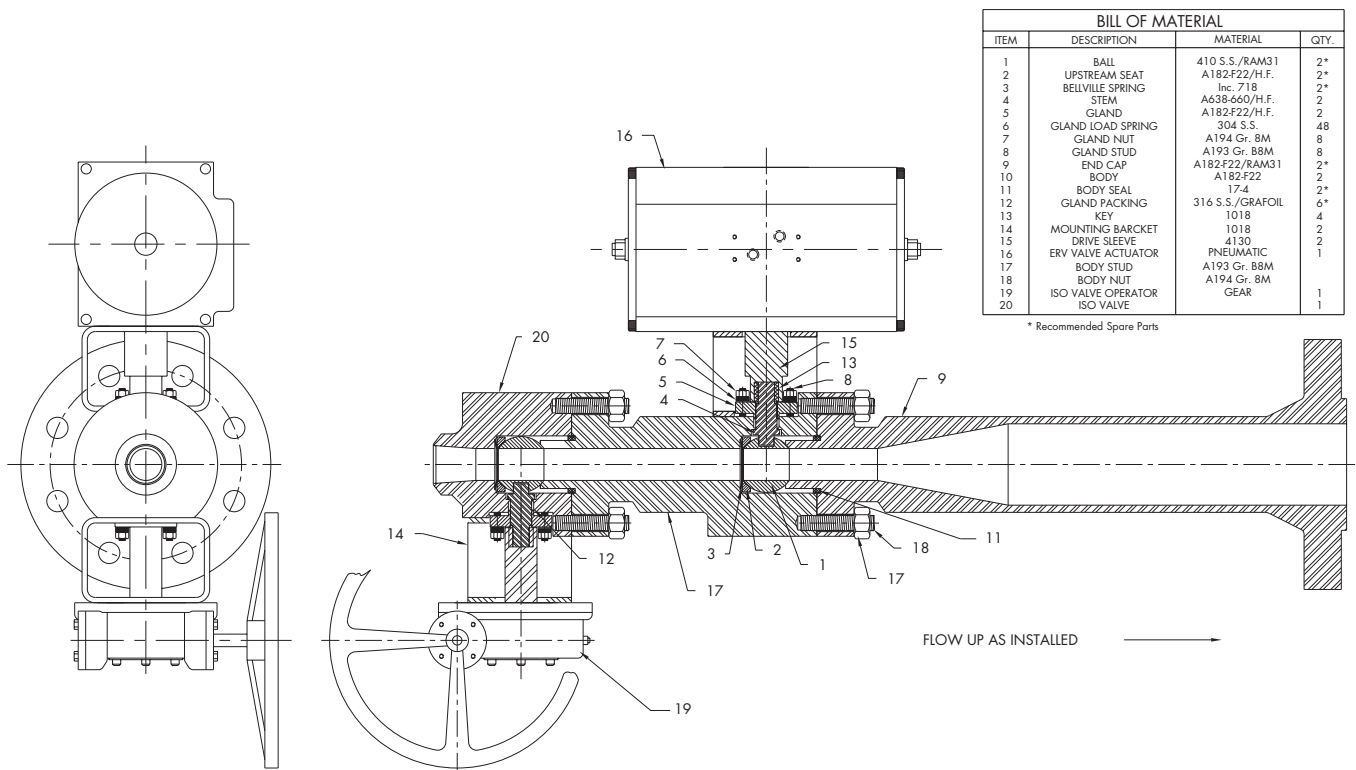

Integral Seat, Four-Year Zero Leakage Guarantee

## Benefits of Valvtechnologies' ERV Controls

- Full pressure protection
- Easily adjusted high and low set points
- Secondary pressure signals can be taken from the boiler nozzle or any other source – customer's choice
- Multiple signals can be prioritized
- Local NEMA IV control box has programmable controller, relays, 4-20ma signal, local/remote selection switch, open and close push buttons (which only work when selector switch is set on manual) and position indicator lights
- The 4-20ma signal from the pressure transducer that is sent to the local controller can also be used in the control room or plugged into the central control computer.
- The Valvtechnologies' standard controls can be adapted to customer requirements, including sliding controls and redundant pressure controls. Overrides can be provided from the control room and local control box.
- DCS signal interfaces are available as are dry and wet contacts.
- Accurate control and repeatable tight shut-off

## "R" SERIES

The "R" Series ERV features a high temperature, double acting rack and pinion operator piped with a solenoid, beacon indicator, limit switches and a terminal box for the wiring connection in the control room.

### The "R" Series ERV features:

- $\pm 1/4\%$  pressure switch that customer connects to a pressure sensing line. The line would need to have an isolation device
- High temperature pneumatic actuator with solenoids and limit switch that contains relevant terminals
- RAM® 31 hardcoating (chrome carbide) on ball and seat
- Terminal box for connections from control room
- Optional siphon and pressure switch
- Optional control box

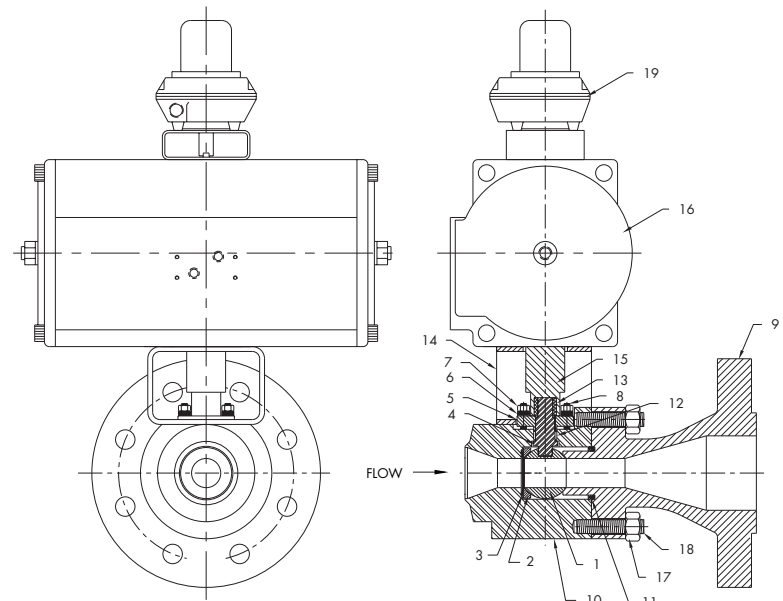

BILL OF MATERIAL			
ITEM	DESCRIPTION	MATERIAL	QTY.
1	BALL	410 S.S./RAM31	1*
2	UPSTREAM SEAT	410 S.S./H.F.	1*
3	BELVILLE SPRING	Inc. 718	1*
4	STEM	A638-660/H.F.	1
5	GLAND	316 S.S./H.F.	1
6	GLAND LOAD SPRING	304 S.S.	24
7	GLAND NUT	A194 Gr. B8M	4
8	GLAND STUD	A193 Gr. B8M	4
9	END CAP	A182F22/RAM31	1*
10	BODY	A182F22	1
11	BODY GASKET	17-4	1
12	GLAND PACKING	316 S.S./GRAFOIL	3*
13	KEY	1018	4
14	MOUNTING BARCKET	1018	1
15	DRIVE SLEEVE	4130	1
16	ACTUATOR	PNEUMATIC	1
17	BODY STUD	A193 Gr. B8M	1
18	BODY NUT	A194 Gr. B8M	1
19	LIMITSWITCH		

\* Recommended Spare Parts

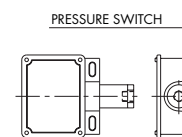

PORV CONTROL BOX

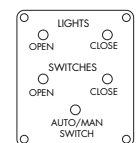

Integral Seat, Four-Year Zero Leakage Guarantee

## Modulating (Sliding) Control Valve & Controller, Positioner, Solenoid

New plants are designed in a way that the superheater vent system is capable of passing larger than normal capacities. In addition, this particular valve can serve as a pressure control function to prevent the superheater safety valves from lifting. However, during a normal small pressure excursion this valve will cycle quickly to the open position. The flow can be large enough to unbalance and trip the system.

The modulating control system eliminates this problem. Assuming the valve needs to be fully open to 105% of normal operating pressure. The valve can be programmed to discharge at a range of capacity from 104% to 105%. An example is if the valve had a total discharge capacity of 500,000 lbs./hr. then at 104%. The valve would be open partially to flow at 100,000 lbs./hr. (example). If this upset continues and the pressure continues to increase, then at 104.3% the valve would discharge at 200,000 lbs./hr. (example). At 104.6 the flow would be 300,000 lbs./hr. and at 105% the valve would fully open to discharge the full capacity of 500,000 lbs./hr.

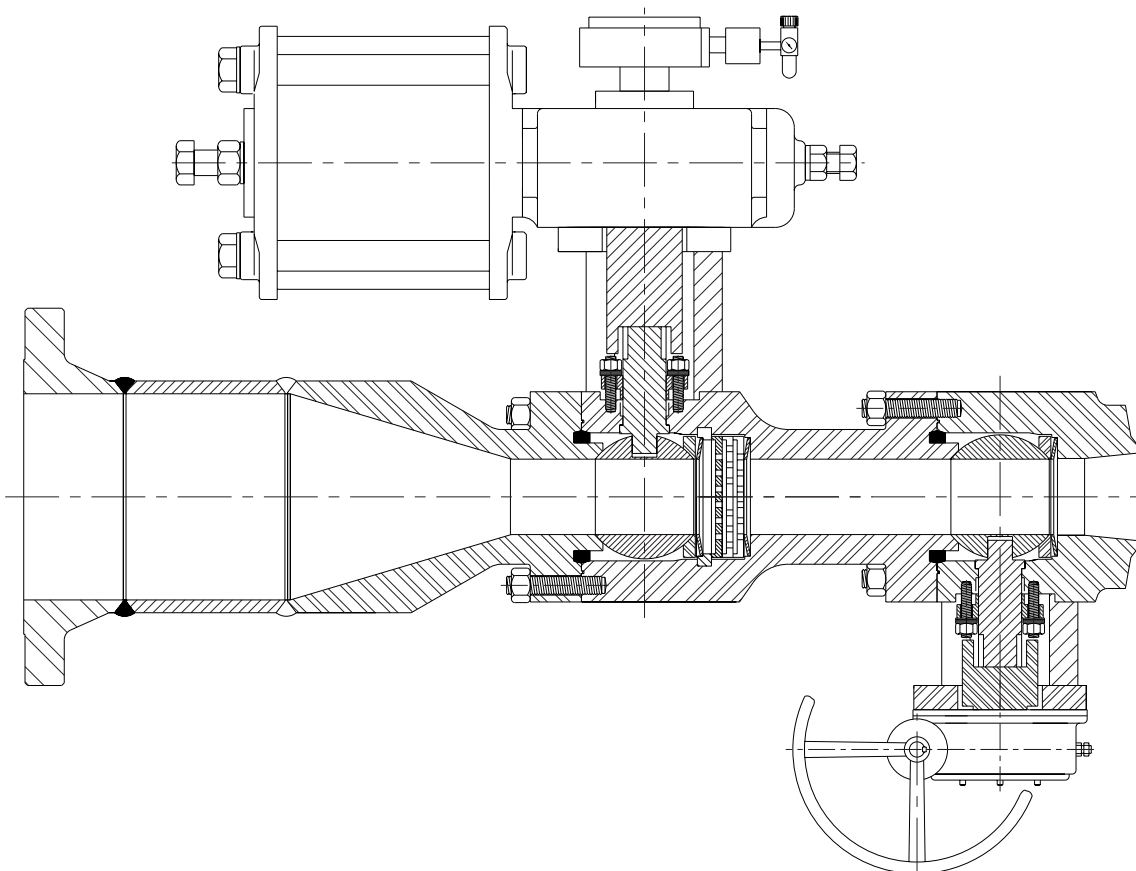

Integral Seat, Four-Year Zero Leakage Guarantee

## Stacked Disc Option for Controlling Applications – Sliding Pressure Control

From simple minimum to normal flow control to full range-ability over any range of pressure drops and conditions; Valvtechnologies has the solution for you.

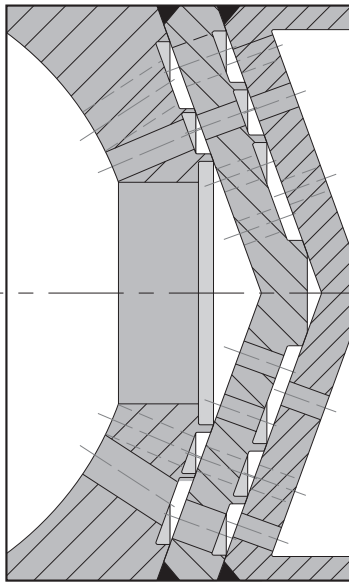

Upstream pressure reducing plates are stacked so maximum flow (pressure) travels through the first plate and then splits and pressure continues to be reduced as flow proceeds to follow tortuous 90° paths through succeeding holes in various stacked pressure reducing plates.

Multi-stage pressure reducing plates are positioned that the diverging streams through the various plates actually collide with each other. This greatly reduces their energy before entering the next plate. Pressure reduction is at the upstream side of the valve, thus reducing the torque required to open and close the valve. The downstream sealing face is protected from flow and offers repeatable tight shut-off.

### ASME B31.1

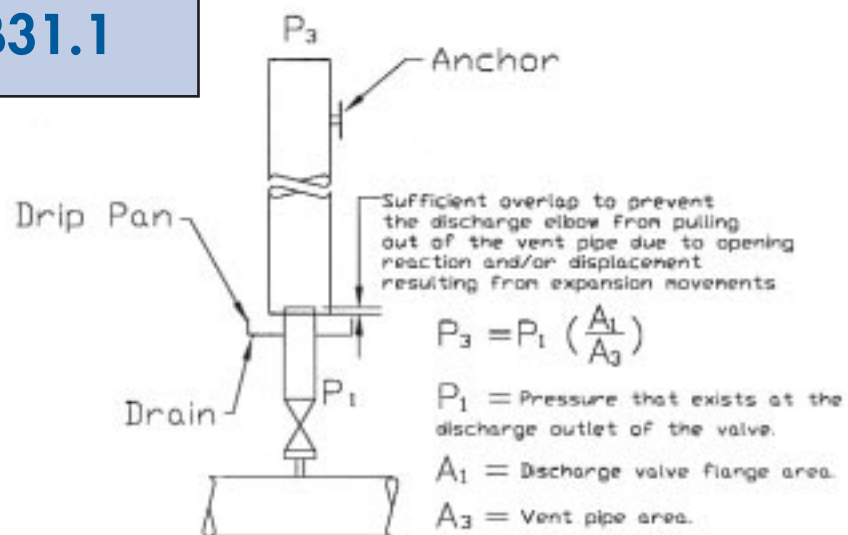

Integral Seat, Four-Year Zero Leakage Guarantee

## Standard Electronic Relief Package

- Valve
- Actuator Options:
  - Air*
  - Spring*
  - Hydraulic*
  - D.C. Electric*
  - A.C. Electric*
  - Fail-Safe Last Position*
  - Fail-Safe*  
*(pneumatic tank or spring return)*
- Pressure Transducer
- Control Box

## Additional Options

- Remote Panel
- Weatherproof Control Box
- Lockable Switch
- Drip Pans/Exhaust Pans
- Voltages
- DCS Signal Input
- Silencers
- Heaters



Represented by:

