

HYGIENIC VALVES

Ideal for CIP operation

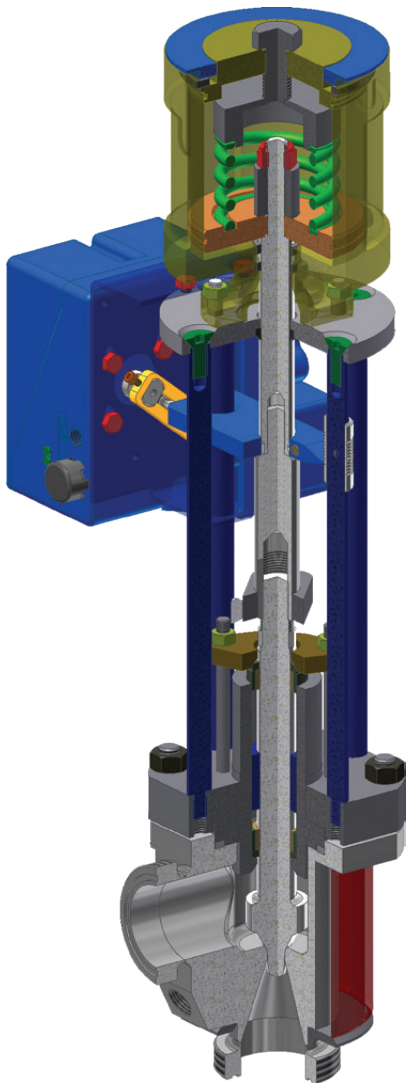

ABOUT HYGIENIC VALVES

Mitech's Hygienic valves are ideal for use in temperatures up to 150°C in the food, brewing and medical industries. The valves are cavity free allowing them to be easily cleaned, while their mirror-polished surface discourages bacteria growth.

The valve body is manufactured in 316 stainless steel and is offered in sizes from 25 mm to 100 mm meeting ANSI # 150 or ND 16 requirements.

Actuators are available with either a double acting or spring return mode with a field reversible fail closed or fail open action. The actuators are rated for 1 000 kPa operation and have Buna N or Viton 'O' ring seals.

SUMMARY OF KEY FEATURES AND BENEFITS

Model	Key features	Key benefits
HYGIENIC VALVES	Mirror polished	Discourages bacteria growth
	Cavity free	Easily cleaned
	Robust design	Long life
	Local manufacture	Quick deliveries - special designs

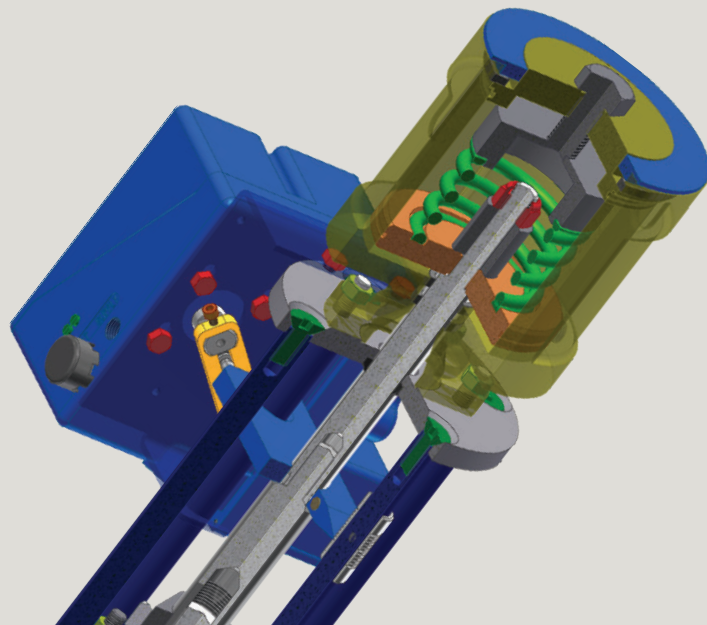

INDUSTRIES AND APPLICATIONS

- Food
- Medical
- Brewing



3-8 Atlas Road
Denel North Entrance (D4)
Kempton Park, 1619
Postnet Suite 8383, Private Bag X32
Kempton Park, 1620
t: 0861 MITECH (648324)
enquiries@mitech.co.za
www.mitech.co.za

