

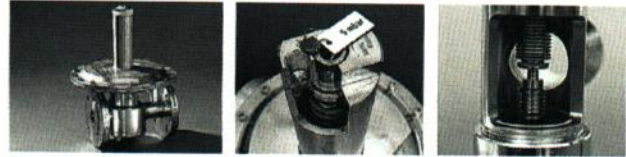

# INSTRUM

BINDERGROUP



## LOW-PRESSURE REDUCER LPR® I in-line design DN 25

### Application

The self contained low pressure reducing regulators and back pressure regulators controls pressure in mbar range. Applications are for inert gas tank blanketing, reactors, centrifuges and agitating tubs with inert gas such as nitrogen. The regulators are designed to meet requirements in the chemical, pharmaceutical and biotechnology industries and are particularly corrosion resistant and reliable.

### Design

The large proportioned, spring-loaded diaphragm actuator with directly-controlled valve seat ensures precise control with low hysteresis. The regulators function without auxiliary power supply. High overpressure strength and safe regulator function is achieved by means of the supported diaphragm with long spindle guide. The regulator has a low degree of clearance volume and is self-draining, as far as is possible.

### Description

The components coming in contact with the product are manufactured from CrNiMo steel 1.4435 / 1.4404. The diaphragm and seals are made of PTFE and the regulator seat is made of perfluoroelastomer (FFKM – Isolast®, Chemraz®, Kalrez®) as standard, or fluoroelastomer (FKM: Viton®). These materials guarantee high corrosion resistance and excellent sealing, even at zero flow. The design has a low degree of clearance volume and is self-draining (suitable for CIP). On request, we can supply regulators in Hastelloy, Tantal or plastic etc. with the appropriate certification. The surface finish for the stainless-steel version is better than Ra 1.6 for housing parts in contact with the medium, better than Ra 0.8 for internal functional parts and better than Ra 3.2 for the outer housing.

### Technical data

<b>Nominal diameter:</b>	DN 25 / 1"
<b>Regulating range P2:</b>	L.. to 500 mbar M.. to 5 bar D (pressure difference) to 4 bar = P3
<b>Inlet pressure P1:</b>	max. 16 bar
<b>Vakuum proof</b>	
<b>Pressure connections:</b>	Flange / thread (Special version available on request)
<b>Weight:</b>	5,3 kg to 7,9 kg
<b>Temperature:</b>	-20 ° to +120 °C for EPDM (Dependent on pressure conditions) -20 ° to +130 °C for FKM -20 ° to +160 °C for PTFE
<b>Testing and inspection:</b>	According to IEC 60534-4
<b>Pressure tightness:</b>	Bubble tight sealing category VI

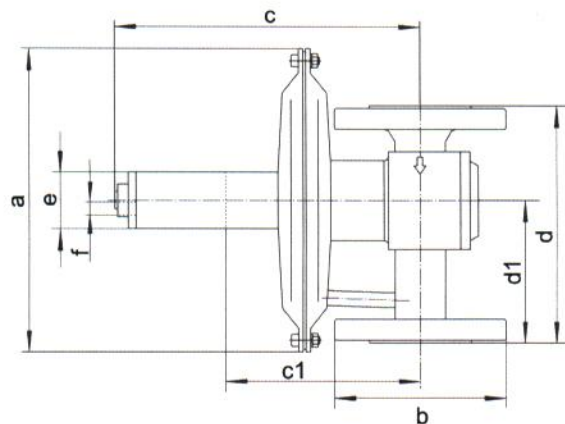
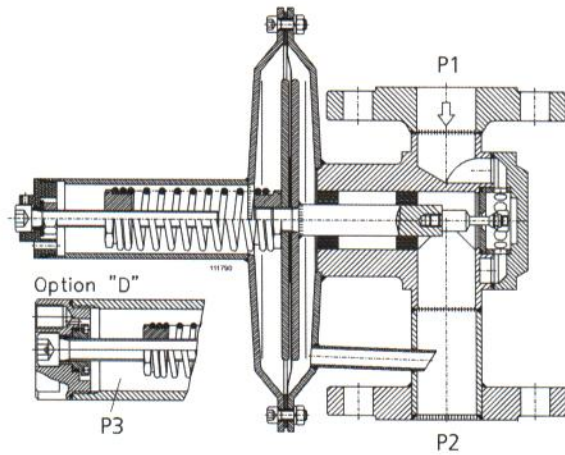
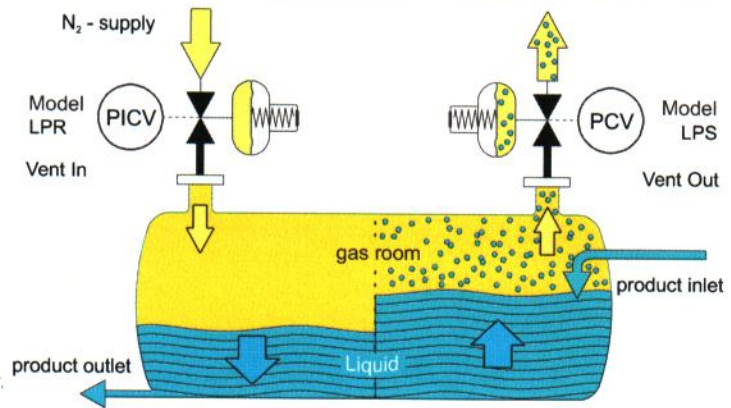

Section drawing for Hastelloy model and regulating pressure range "M" available on request.

Model dimensions	pressure connection	a	b	c	d	d1	e	f Option "D"	c1 factory setting P2
LPRI-025.-.-L.-.-	DIN DN25 PN16 ANSI 1" 150 lbs	∅ 204	∅115 (DIN)	207	160	96	∅38 (M36)	G 1/4" female thread (dimension "e" is always ∅54 (M48) with Option "D")	149
LPRI-025.-.-M.-.-	BSP 1" female thread NPTF 1" female thread	∅ 115	∅108 (ANSI)	230			∅54 (M48)		





## MODEL CODE LPR®

in-line design  
DN 25

1		2			3		4			5		6		7
Design		Nominal diameter DN/ pressure connection			Flow capacity		Regulating pressure range			Material		Options		Specials
LP	R I -	025	.	-	..	-	...	-	...	-	.	-	Xn	

### 2 Nominal diameter DN/ Pressure connection

D	Flange:	DIN EN 1092-1, B1 DN 25 PN 16
A	Flange:	ANSI B 16.5, 1" 150 lbs
B	Thread:	1" BSP female thread
N	Thread:	1" NPTF female thread

### 3 Flow capacity

04	Seat	ø4 mm
07	Seat	ø7 mm
12	Seat	ø12 mm
16	Seat	ø16 mm

### 4 Regulating pressure range P2 (mbar)

L01	2 - 10	L50	80 - 500
L02	4 - 20	M01	200 - 1000
L05	8 - 50	M03	500 - 3000
L10	16 - 100	M05	800 - 5000
L20	30 - 200		

### 5 Material (only the same colours can be combined)

Housing/ internal components	Seat seal	Diaphragm/ Regulating range
S 1.4435 (1.4404)/ 1.4435 (1.4404)	K FFKM	P PTFE L..
G 1.4435 (1.4404)/ HC 22 (2.4602)	V FKM	E EPDM L.. M..
H 1 HC 22 (2.4602)/ HC 22 (2.4602)	E EPDM	G PTFE-glass fibre reinforced / L..
	C FFKM conforms to FDA	V FKM M..
		H <sup>2</sup> HC 276 M..

<sup>1</sup> Not available with seat 04.

<sup>2</sup> Cannot be combined with seat seal "V" or "E".

**Example:** Housing/internal components with material code "G" or "H" (red) are only combined with seat of type "K" or "C" and with diaphragm type "P" or "G".

Housing/internal components with material code "S" can be combined with all seat and diaphragm materials (yellow). Notice footnote <sup>2</sup>.

### 6 Options

D	Differential pressure connection
E	NPT ¼" external impulse connection
G	Pressure gauge connection G ¾"

### 7 Specials

X0	If you require, for example, ATEX, PED, special connections, external control, rain hood, a fixed setting for P2 ..., please enter an X in this field with the number of desired Specials. Each of the specials must be described in writing.
X1	
X2	
Xn	For special versions and certifications, please contact the manufacturer or the appropriate sales representative.

### Flow table [flow quantities in Nm³/h]

P1 [bar rel.]	0.16	0.25	0.40	0.65	1.0	1.6	2.5	4	6	10	Seat size
10	3,4	5,4	7	9	10,5	14	19	26	38	-	ø4 mm
	12	16	20	24	30	40	70	100	135	-	ø7 mm
	34	50	70	95	125	155	220	300	400	-	ø12 mm
	70	90	120	160	195	260	390	-	-	-	ø16 mm
100	3,6	5,4	7	9	10,5	14	19	26	38	-	ø4 mm
	12	15	19	24	29	39	65	90	130	-	ø7 mm
	34	50	70	95	125	160	220	290	390	-	ø12 mm
	70	90	120	165	190	260	390	-	-	-	ø16 mm
200	-	12	18	23	29	38	60	100	140	-	ø7 mm

The flow capacity is the same in the supercritical operating range (guide value: P2 < 0.5 x P1).

It is recommended to design for operation at a maximum of 70% of the flow values.

If the diaphragm is designed in M / HC, the flow is reduced by 50 %.

P1 = supply pressure P2 = regulating pressure

### Dependency on inlet pressure (per -1 bar / +1 bar change in P1)

Seat ø4 mm	+1 mbar / -1 mbar	Seat ø12 mm	+8 mbar / -8 mbar
Seat ø7 mm	+3 mbar / -3 mbar	Seat ø16 mm	+13 mbar / -13 mbar

### Pressure / flow characteristic

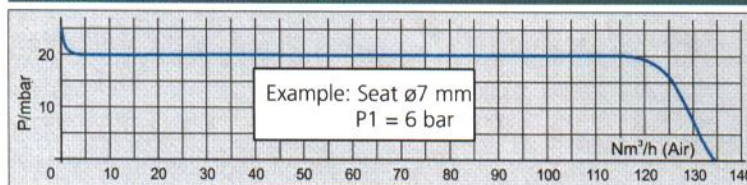

### Installation

The preferred installation position is with vertical diaphragm housing and horizontal input.

Pressure fixed unit is adjusted in this position.

The output pressure increases by approximately

4 mbar for installation with horizontal diaphragm housing.

The installation position must be specified.

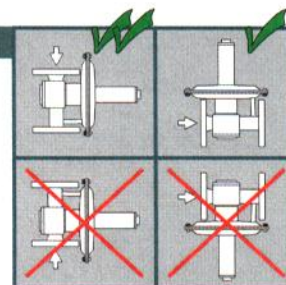

### Mounting and start up

- Before connecting the pressure regulator please make sure
  - to compare the plant data with the name plate
  - the values marked on the name plate are the values measured during our functional inspection
  - to check the corrosion resistance of the material
  - to blow out impurities in the pipes
  - to note the flow direction – it is marked with an arrow on the housing
  - to open inlet pipes slowly.
- LPRI adjust reduced pressure: (Relative pressure)
  - set a light flow (1Nm³/h). Set the pressure +/- as required using a hexagonal wrench
  - the setting can be secured with a seal.
- Adjust the LPRI differential pressure (-D) with the servo-regulator
  - if the D-connection is pressurised with the servo-pressure, the working pressure is added by the servo-pressure.