

ORIFICE PLATES & FLANGES

Types: BLS & MBL



Technical Information

03/2011



FLOW

Intra-Automation
Technical Information
03/2011

Technical details subject to be changed without notice.

For comments regarding this brochure, please contact:
info@intra-automation.de

Types: BLS & MBL

ORIFICE PLATES & FLANGES

List of contents

Chapt.	Content	Page
1	Differential pressure and pressure loss	3
2	Orifice plate type: BLS-100-RF	4
2.1	Description	4
2.2	Specification	4
2.3	Types	5
2.4	Ordering code	6
3	Orifice plate with ring type: BLS-200	7
3.1	Description	7
3.2	Specification	7
3.3	Ordering code	8
4	Orifice plate with integral ring type: BLS-250	9
4.1	Description	9
4.2	Specification	9
4.3	Ordering code	10
5	Orifice plate with holding Ring type: BLS-100-RTJ	11
5.1	Description	11
5.2	Specification	11
5.3	Ordering code	12
6	Orifice flange assemblies type: BLS 300	13
6.1	Description	13
6.2	Specification	13
6.3	Pressure ratings / facing	13
6.4	Types	14
6.5	Orifice flange dimensions	15
6.6	Ordering code	22
7	Pressure tap connections	38
8	Orifice meter runs type: MBL-500	40
8.1	Description	40
8.2	Type and drawing	40
8.3	Ordering code	41

1 Differential pressure and pressure loss

When a throttle element is interposed in a closed passage of fluid in piping, a difference is produced between the pressure upstream and downstream the throttle element as illustrated in **Fehler! Verweisquelle konnte nicht gefunden werden..** This difference ($h=p_1-p_2$) is called differential pressure. The fluid passing through the section 2 gradually regains its pressure as it flows downstream, but the downstream pressure cannot be recovered up to the upstream pressure, part of the pressure being lost. This loss is called pressure loss (permanent pressure loss= p_1-p_3).

The extent of this pressure loss depends on the type of throttle elements and their open area ratio, as shown in **Fehler! Verweisquelle konnte nicht gefunden werden..**

The relation between the flow rate and the differential pressure is given by:

$$V = k * \sqrt{\frac{\Delta p}{\rho_1}} \quad (1)$$

$$V_N = k * \sqrt{\frac{\Delta p * \rho_1}{\rho_N}} \quad (2)$$

$$M = k * \sqrt{\Delta p * \rho_1} \quad (3)$$

with:

- \dot{V} [m³/h] : volume rate of flow at density under operating conditions
- \dot{V}_N [Nm³/h] : volume rate of flow at density under standard conditions
- M [kg/h] : mass flow
- Δp [kg/m²] : differential pressure
- ρ_1 [kg/m³] : density under operating conditions
- ρ_N [kg/Nm³] : density under standard conditions
- k [] : coefficient (determined by type and size of throttle element).

From the above, the relation between the flow rate and the differential pressure where the density is constant but the flow rate is variable is as listed in **Fehler! Verweisquelle konnte nicht gefunden werden..** In other words, the flow rate is obtainable by measuring the differential pressure. When the density is variable (when pressure and temperature are variable), the true flow rate can be given by compensating the variation of the density by the above equations (this, however, is not applicable when the density varies to a great extent).

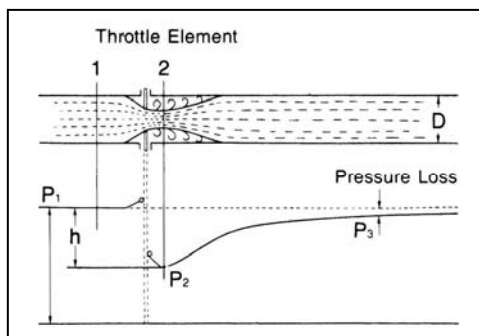

Fig. 1

Flow [%]	Dp [%]
100	100
90	81
80	64
70	49
60	36
50	25
40	16
30	9
20	4
10	1
0	0

Table 1

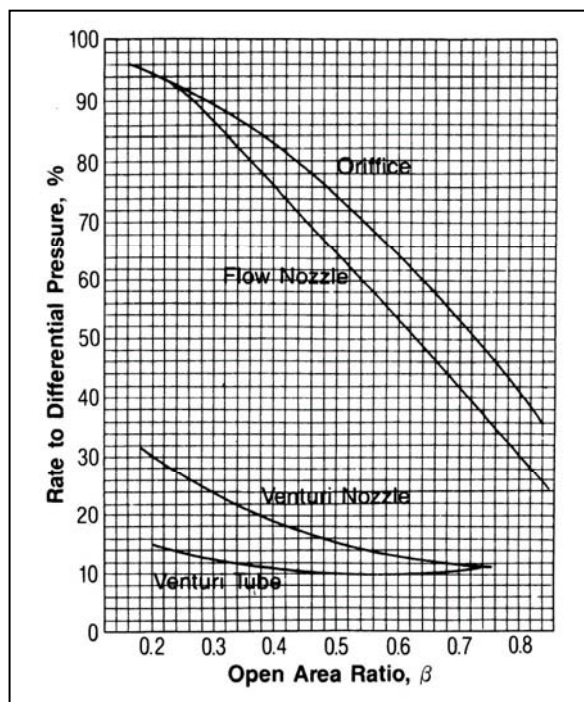

Fig. 2

2 Orifice plate, type: BLS-100-RF

2.1 Description

Orifice plates have a disadvantage of permitting a greater pressure loss than other throttle elements (flow nozzles, venturi tubes, ITABAR, etc.) but are most popularly used because of their simpler shape, easier manufacturability, lower cost and higher reliability.

The types of orifice plates include concentric, eccentric, segmental, quarter-circle and square orifice plate, etc..

2.2 Specification

- **orifice bore type:**
 - concentric square edged orifices
 - quadrant edged orifices
 - eccentric orifices
 - segmental orifices
 - minimum quadrant edged orifice diameter 4.5 mm
- **flow calculation standards:**
 - concentric square edged orifices:
 - ISO-5167-1991; ASME-1991; JIS Z 8762-1988
 - 1D-1/2D (radius) tap and 2.5D-8D (pipe) tap are per "ASME Fluid Meters, Their Theory and Application, 5th Edition, 1959"
 - eccentric orifices/ segmental orifices:
 - ASME Fluid Meters, Their Theory and Application, 5th Edition, 1959
 - Note: ASME-1991, JIS Z 8762-1988 flow data used to calculate orifice bore is identical to that of ISO-5167-1991*
- **flange ratings:**
 - ANSI Class 150: 300, 600 and 900 (RF)
 - DIN PN16, 40, 63
- **pressure taps:**
 - flange tap
 - corner tap
 - 1D and 1/2D (Radius) tap
- **plate thickness:**
 - 3, 6, 9, 12mm, etc.
- **tab handle:**
 - welded to orifice plate
- **materials:**
 - plate DIN 1.4571, 1.5415, etc.
 - ASTM 304, 316SS, 316Ti, etc.
- **drain and vent hole :**
 - per ISA-RP3.2 recommendations. Not drilled for orifice bore smaller than 25.4 mm
- **markings:**
 - Upstream side of tab handle stamped "+" and with bore type and size, line size, TAG no., quadrant edge radius and flange rating, orifice material and serial number.
 - Downstream side of tab handle stamped with "-".
- **Special markings:**
 - special marking may be furnished to meet specific requirements

2.3 Types

- **concentric**
This has special features such as simple structure, high accuracy, easy mounting and dismounting. The orifice plates are correctly finished to the dimensions, surface roughness and flatness to the applicable standard.
Differential pressure is measured through flange, vena contracta, radius or corner taps.
- **Eccentric**
For liquids containing solid particles that are likely to sediment or for vapors likely to deposit water condensate, this orifice plate is used with its eccentric bore bottom flush with the bottom of the piping surface so that the sedimentation of such inclusions is avoided. Likewise, for gases or vapors, it may be installed with its eccentric bore top flush with the bore top of the piping to avoid the stay of gas or vapor in its vicinity. Flange taps or vena contracta taps are used for the orifice plate.
- **Segmental**
The bore of the orifice plate is a semicircle to perform the same function as the eccentric orifice plate. This is used for similar purposes.
Flange taps or vena contracta taps are employed to take out fluid pressures.
- **Quarterant**
The inlet edge of the bore of this orifice plate is rounded to a quarter circle. This orifice plate is principally used for measuring flow rates of low Reynolds numbers.
Flange taps or corner taps are used.

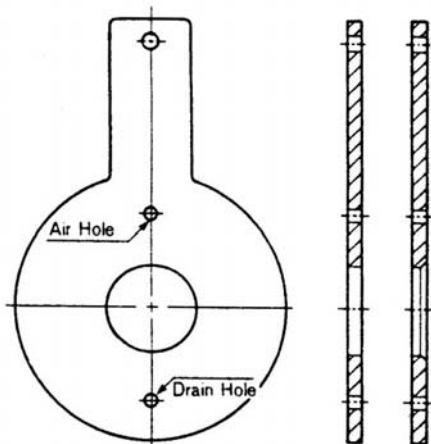

Fig 3

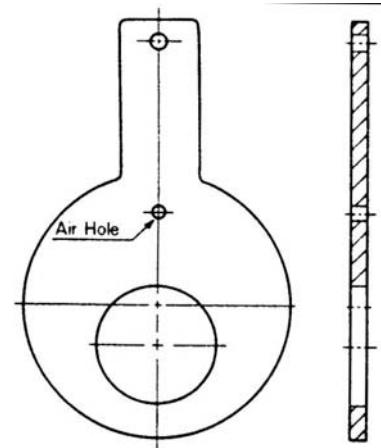

Fig 4

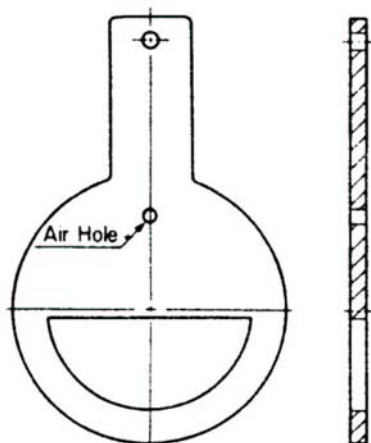

Fig 5

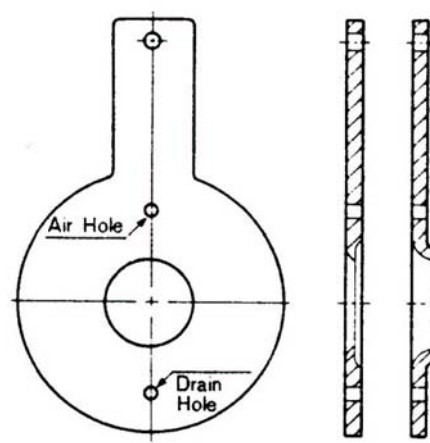

Fig 6

2.4 Ordering codes

Code	Description					
BLS	Orifice plate acc. EN ISO 5167-1					
1. Installation between DIN / ANSI flanges Form C/RF/RTJ						
100	Standard					
2. Flanges						
DC	acc. to DIN with flange facing form C					
AF	acc. to ANSI with flange facing RF					
AJ	acc. to ANSI with flange facing RTJ					
3. Orifice calculation by Intra						
0	without					
M	with					
4. Documentation						
0	without					
1	Material certificates acc. DIN EN 10204-2.2					
2	Material certificates acc. DIN EN 10204-3.1					
5. Connection dimension						
PN10-16/150 lbs, mat. 316L			PN10-16/150 lbs, mat. 316Ti			
A1	DN50 / 2"		B1	DN50 / 2"		
A2	DN65 / 2 1/2"		B2	DN65 / 2 1/2"		
A3	DN80 / 3"		B3	DN80 / 3"		
A4	DN100 / 4"		B4	DN100 / 4"		
A5	DN125 / 5"		B5	DN125 / 5"		
A6	DN150 / 6"		B6	DN150 / 6"		
A7	DN200 / 8"		B7	DN200 / 8"		
A8	DN250 / 10"		B8	DN250 / 10"		
A9	DN300 / 12"		B9	DN300 / 12"		
A10	DN350 / 14"		B10	DN350 / 14"		
A11	DN400 / 16"		B11	DN400 / 16"		
A12	DN500 / 20"		B12	DN500 / 20"		
A13	DN600 / 24"		B13	DN600 / 24"		
A14	DN700 / -		B14	DN700 / -		
A15	DN800 / -		B15	DN800 / -		
PN40/300 lbs, mat. 316L			PN40/300 lbs, mat. 316Ti			
C1	DN50 / 2"		D1	DN50 / 2"		
C2	DN65 / 2 1/2"		D2	DN65 / 2 1/2"		
C3	DN80 / 3"		D3	DN80 / 3"		
C4	DN100 / 4"		D4	DN100 / 4"		
C5	DN125 / 5"		D5	DN125 / 5"		
C6	DN150 / 6"		D6	DN150 / 6"		
C7	DN200 / 8"		D7	DN200 / 8"		
C8	DN250 / 10"		D8	DN250 / 10"		
C9	DN300 / 12"		D9	DN300 / 12"		
C10	DN350 / 14"		D10	DN350 / 14"		
C11	DN400 / 16"		D11	DN400 / 16"		
C12	DN500 / 20"		D12	DN500 / 20"		
C13	- / 24"		D13	- / 24"		
PN64-100/600 lbs, mat. 316L			PN64-100/600 lbs, mat. 316Ti			
E1	DN50 / 2"		F1	DN50 / 2"		
E2	DN65 / 2 1/2"		F2	DN65 / 2 1/2"		
E3	DN80 / 3"		F3	DN80 / 3"		
E4	DN100 / 4"		F4	DN100 / 4"		
E5	DN125 / 5"		F5	DN125 / 5"		
E6	DN150 / 6"		F6	DN150 / 6"		
E7	DN200 / 8"		F7	DN200 / 8"		
E8	DN250 / 10"		F8	DN250 / 10"		
E9	DN300 / 12"		F9	DN300 / 12"		
E10	DN350 / 14"		F10	DN350 / 14"		
E11	DN400 / 16"		F11	DN400 / 16"		
E12	- / 20"		F12	- / 20"		
E13	- / 24"		F13	- / 24"		
Special materials						
G1-G..	Hastelloy					
H1-H..	Other special materials					
BLS	100					
BLS	100	A	M	2	D8	example

3 Orifice plate with ring, type BLS-200

3.1 Description

Orifice ring assemblies are used for flow measurement of smaller or medium sized pipes at lower pressures. Each assembly consists of one orifice plate and two orifice rings. Differential pressures are taken out in a corner tap system. Orifice blocks, which are of a unit-construction type and provide higher pressure ratings than the orifice ring assemblies, also are available. Differential pressures are taken out in a corner tap system.



3.2 Specification

- **orifice bore type:**
concentric square edged orifices
quadrant edged orifices
minimum quadrant edged orifice diameter 4.5 mm
minimum quadrant edge radius 0.5 mm
- **flow calculation standards:**
concentric square edged orifices:
ISO-5167-1991; ASME-1991; JIS Z 8762-1988
1D-1/2D (radius) tap and 2.5D-8D (pipe) tap are per "ASME Fluid Meters, Their Theory and Application, 5th Edition, 1959"
Note: ASME-1991, JIS Z 8762-1988 flow data used to calculate orifice bore is identical to that of ISO-5167-1991
- **flange ratings:**
ANSI (or JPI) Class 150
DIN PN16
Note: ANSI and JPI ring dimensions are identical.)
- **pressure taps:**
corner tap
- **plate thickness:**
3, 6, 9, 12mm, etc.
- **tab handle:**
welded to orifice plate
- **pressure tap handle:**
15 mm (1/2") Sch80
length 150 mm
tap connections 1/2"-NPT-male, socket weld, butt weld or flange (Flange rating to be the same as the of the process pipeline.)
- **materials:**
ring and pressure tap nipple : carbon steel, ASTM 304SS, 316SS; DIN 1.4571, etc.
plate : ASTM 304, 316SS, 316Ti ; DIN 1.4571, 1.5415, etc.
tab handle : ASTM 304, 316SS, 316Ti ; DIN 1.4571, 1.5415, etc.
- **drain and vent hole :**
per ISA-RP3.2 recommendations. Not drilled for orifice bore smaller than 25.4 mm
- **markings:**
Upstream side of tab handle stamped "+" and with bore type and size, line size, TAG no., quadrant edge radius and flange rating, orifice material and serial number.
Downstream side of tab handle stamped with "-".
- **Special markings:**
special marking may be furnished to meet specific requirements
- **Gasket:**
non-asbestos with 1.5mm thickness

3.3 Ordering codes

Code	Description
BLS	Orifice plate with ring acc. EN ISO 5467-1
	1. Installation between smooth DIN / ANSI flanges Form C/RF
200	Standard
	2. Flanges
D	Flange face acc. DIN
A	Flange face acc. ANSI
	3. Orifice calculation by Intra
0	without
M	with
	4. Documentation
0	without
1	Material certificates acc. DIN EN 10204-2.2
2	Material certificates acc. DIN EN 10204-3.1
	5. Material orifice plate
1	316L
2	316Ti
	6. Pressure rating / Flange face
	acc. to DIN
1	PN10 / Form C
2	PN16 / Form C
3	PN40 / Form C
4	PN64 / Form E
5	PN100 / Form E
6	PN160 / Form E
	acc. to ANSI
150#	RF
300#	RF
600#	RF
900#	RF
	7. Connection dimension / material ring and tap
A1	DN50 / 2" HII
A2	DN50 / 2" CS
A3	DN50 / 2" 316Ti
B1	DN65 / 2 1/2" HII
B2	DN65 / 2 1/2" CS
B3	DN65 / 2 1/2" 316Ti
C1	DN80 / 3" HII
C2	DN80 / 3" CS
C3	DN80 / 3" 316Ti
D1	DN100 / 4" HII
D2	DN100 / 4" CS
D3	DN100 / 4" 316Ti
E1	DN125 / 5" HII
E2	DN125 / 5" CS
E3	DN125 / 5" 316Ti
F1	DN150 / 6" HII
F2	DN150 / 6" CS
F3	DN150 / 6" 316Ti
G1	DN200 / 8" HII
G2	DN200 / 8" CS
G3	DN200 / 8" 316Ti
H1	DN250 / 10" HII
H2	DN250 / 10" CS
H3	DN250 / 10" 316Ti
J1	DN300 / 12" HII
J2	DN300 / 12" CS
J3	DN300 / 12" 316Ti
K1	DN350 / 14" HII
K2	DN350 / 14" CS
K3	DN350 / 14" 316Ti
L1	DN400 / 16" HII
L2	DN400 / 16" CS
L3	DN400 / 16" 316Ti
M1	DN500 / 20" HII
M2	DN500 / 20" CS
M3	DN500 / 20" 316Ti
N1	DN600 / 24" HII
N2	DN600 / 24" CS
N3	DN600 / 24" 316Ti
P1	DN700 / 28" HII
P2	DN700 / 28" CS
P3	DN700 / 28" 316Ti
Q1	DN800 / 32" HII
Q2	DN800 / 32" CS
Q3	DN800 / 32" 316Ti

BLS	-200								
BLS	-200	A	M	2	2	1	E1	Example	

4 Orifice plate with integral ring, type: BLS-250

4.1 Description

Orifice plate with integral ring is a different pressure type primary device used to produce a fluid flow restriction in a pipeline. The differential pressure across the orifice plate is proportional to the square of the fluid velocity. The differential pressure is applied to the integral pressure taps through single holes in the corner formed by the ring wall and the orifice plate.

The orifice plate with ring is cut and shaped from on block of metal. The pressure tap nipples are welded to the orifice plate and ring. Orifice plate with integral ring is suitable for high pressure and temperature service applications and similar to the orifice plate with ring.



4.2 Specification

- **orifice bore type:**
concentric square edged orifices
quadrant edged orifices
- **flow calculation standards:**
concentric square edged orifices:
ISO-5167-1991; ASME-1991; JIS Z 8762-1988
Note: ASME-1991, JIS Z 8762-1988 flow data used to calculate orifice bore is identical to that of ISO-5167-1991
- **flange ratings:**
ANSI (or JPI) Class 300, 600 and 900 (RF)
DIN PN40, 63, 100
Note: ANSI and JPI ring dimensions are identical.)
- **pressure taps:**
single hole type corner taps. Annular chamber type corner taps
- **nominal pipe sizes:**
15 to 400 mm (½" to 16")
- **pressure tap nipple**
15mm (½ ") Sch80, length 150 mm
- **tap connections:**
½"-NPT-male, socket weld, butt weld or flange (Flange rating to be the same as the of the process pipeline.). Angle between two taps is a straight angle.
- **materials:**
plate and nipple: ASTM 304SS, 316SS; DIN 1.4571, etc.
- **markings:**
ring rim stamped with TAG no., bore size, flow direction, material, line size, flange rating and serial number.

4.3 Ordering codes

Code	Description
BLS	Orifice plate with ring acc. EN ISO 5467-1
	1. Installation between smooth DIN / ANSI flanges Form C/RF
200	Standard
	2. Flanges
D	Flange face acc. DIN
A	Flange face acc. ANSI
	3. Orifice calculation by Intra
0	without
M	with
	4. Documentation
0	without
1	Material certificates acc. DIN EN 10204-2.2
2	Material certificates acc. DIN EN 10204-3.1
	5. Material orifice plate
1	316L
2	316Ti
	6. Pressure rating / Flange face
	acc. to DIN
1	PN10 / Form C
2	PN16 / Form C
3	PN40 / Form C
4	PN64 / Form E
5	PN100 / Form E
6	PN160 / Form E
	acc. to ANSI
1	150# / RF
2	150# / RF
3	300# / RF
4	600# / RF
5	600# / RF
6	900# / RF
	7. Connection dimension / material ring and tap
A1	DN50 / 2" HII
A2	DN50 / 2" CS
A3	DN50 / 2" 316Ti
B1	DN65 / 2 1/2" HII
B2	DN65 / 2 1/2" CS
B3	DN65 / 2 1/2" 316Ti
C1	DN80 / 3" HII
C2	DN80 / 3" CS
C3	DN80 / 3" 316Ti
D1	DN100 / 4" HII
D2	DN100 / 4" CS
D3	DN100 / 4" 316Ti
E1	DN125 / 5" HII
E2	DN125 / 5" CS
E3	DN125 / 5" 316Ti
F1	DN150 / 6" HII
F2	DN150 / 6" CS
F3	DN150 / 6" 316Ti
G1	DN200 / 8" HII
G2	DN200 / 8" CS
G3	DN200 / 8" 316Ti
H1	DN250 / 10" HII
H2	DN250 / 10" CS
H3	DN250 / 10" 316Ti
J1	DN300 / 12" HII
J2	DN300 / 12" CS
J3	DN300 / 12" 316Ti
K1	DN350 / 14" HII
K2	DN350 / 14" CS
K3	DN350 / 14" 316Ti
L1	DN400 / 16" HII
L2	DN400 / 16" CS
L3	DN400 / 16" 316Ti
M1	DN500 / 20" HII
M2	DN500 / 20" CS
M3	DN500 / 20" 316Ti
N1	DN600 / 24" HII
N2	DN600 / 24" CS
N3	DN600 / 24" 316Ti
P1	DN700 / 28" HII
P2	DN700 / 28" CS
P3	DN700 / 28" 316Ti
Q1	DN800 / 32" HII
Q2	DN800 / 32" CS
Q3	DN800 / 32" 316Ti

BLS	-200								
BLS	-200	A	M	2	2	1	E1	Example	

5 Orifice plate with holding ring, type BLS-100-RTJ

5.1 Description

The holding ring assembly is a combination of a holding ring and an orifice plate designed for ring-type-joint (RTJ) flanges of ANSI or JPI specifications. The holder ring has a function of holding the orifice plate and also a function as a gasket to prevent leakage of the process fluid. This metallic sealing system is applicable to a fluid of high temperature and high pressure. The pressure tapping system normally is of the flange tap type.

5.2 Specifications

- **orifice bore type:**
concentric square edged orifices
quadrant edged orifices
- **flow calculation standards:**
concentric square edged orifices:
ISO-5167-1991; ASME-1991; JIS Z 8762-1988
Note: ASME-1991, JIS Z 8762-1988 flow data used to calculate orifice bore is identical to that of ISO-5167-1991
- **flange ratings:**
ANSI (or JPI) Class 300, 600 and 900 (RF)
DIN PN40, 63, 100
Note: ANSI and JPI ring dimensions are identical.)
- **pressure taps:**
flange taps
- **plate thickness:**
3, 6, 9, 12 mm etc.
- **tab handle:**
welded to ring
- **holding ring:**
riveted to plate, octagonal or oval
- **drain and vent hole:**
per ASME recommendations. No drill for orifice bores smaller than 25.4 mm
- **materials:**
plate: ASTM 304SS, 316SS; DIN 1.4571, etc.
holding ring: ASTM 304SS, 316SS; DIN 1.4571, etc.
- **markings:**
Upstream side of tab handle stamped "+" and with bore type and size, line size, TAG no., quadrant edge radius and flange rating, orifice material and serial number.
Downstream side of tab handle stamped with "-".
- **Special markings:**
special marking may be furnished to meet specific requirements.



Nominal pipe size available:

Orifice bore type	Pipe size	Pipe diameter given in the applicable standards
Concentric square edge	1 ½" to 14"	50 to 760 mm
Quadrant edge	1 ½" to 6"	25 to 150 mm

5.4 Ordering codes

Code	Description
BLS	Orifice plate acc. EN ISO 5167-1
1. Installation between DIN / ANSI flanges Form C/RF/RTJ	
100	Standard
2. Flanges	
DC	acc. to DIN with flange facing form C
AF	acc. to ANSI with flange facing RF
AJ	acc. to ANSI with flange facing RTJ
3. Orifice calculation by Intra	
0	without
M	with
4. Documentation	
0	without
1	Material certificates acc. DIN EN 10204-2.2
2	Material certificates acc. DIN EN 10204-3.1
5. Connection dimension	
PN10-16/150 lbs, mat. 316L	
A1	DN50 / 2"
A2	DN65 / 2 1/2"
A3	DN80 / 3"
A4	DN100 / 4"
A5	DN125 / 5"
A6	DN150 / 6"
A7	DN200 / 8"
A8	DN250 / 10"
A9	DN300 / 12"
A10	DN350 / 14"
A11	DN400 / 16"
A12	DN500 / 20"
A13	DN600 / 24"
A14	DN700 / -
A15	DN800 / -
PN10-16/150 lbs, mat. 316Ti	
B1	DN50 / 2"
B2	DN65 / 2 1/2"
B3	DN80 / 3"
B4	DN100 / 4"
B5	DN125 / 5"
B6	DN150 / 6"
B7	DN200 / 8"
B8	DN250 / 10"
B9	DN300 / 12"
B10	DN350 / 14"
B11	DN400 / 16"
B12	DN500 / 20"
B13	DN600 / 24"
B14	DN700 / -
B15	DN800 / -
PN40/300 lbs, mat. 316L	
C1	DN50 / 2"
C2	DN65 / 2 1/2"
C3	DN80 / 3"
C4	DN100 / 4"
C5	DN125 / 5"
C6	DN150 / 6"
C7	DN200 / 8"
C8	DN250 / 10"
C9	DN300 / 12"
C10	DN350 / 14"
C11	DN400 / 16"
C12	DN500 / 20"
C13	- / 24"
PN40/300 lbs, mat. 316Ti	
D1	DN50 / 2"
D2	DN65 / 2 1/2"
D3	DN80 / 3"
D4	DN100 / 4"
D5	DN125 / 5"
D6	DN150 / 6"
D7	DN200 / 8"
D8	DN250 / 10"
D9	DN300 / 12"
D10	DN350 / 14"
D11	DN400 / 16"
D12	DN500 / 20"
D13	- / 24"
PN64-100/600 lbs, mat. 316L	
E1	DN50 / 2"
E2	DN65 / 2 1/2"
E3	DN80 / 3"
E4	DN100 / 4"
E5	DN125 / 5"
E6	DN150 / 6"
E7	DN200 / 8"
E8	DN250 / 10"
E9	DN300 / 12"
E10	DN350 / 14"
E11	DN400 / 16"
E12	- / 20"
E13	- / 24"
PN64-100/600 lbs, mat. 316Ti	
F1	DN50 / 2"
F2	DN65 / 2 1/2"
F3	DN80 / 3"
F4	DN100 / 4"
F5	DN125 / 5"
F6	DN150 / 6"
F7	DN200 / 8"
F8	DN250 / 10"
F9	DN300 / 12"
F10	DN350 / 14"
F11	DN400 / 16"
F12	- / 20"
F13	- / 24"
Special materials	
G1-G..	Hastelloy
H1-H..	Other special materials

BLS	100					
BLS	100	A	M	2	D8	example

6 Orifice flange assemblies, type: BLS-300

6.1 Description

Orifice flange assemblies are used in conjunction with orifice plates for flow measurement of smaller or medium size pipes at lower or medium pressure ranges. The flange connection is of a RF type and the differential pressure tapping system is with flange taps.

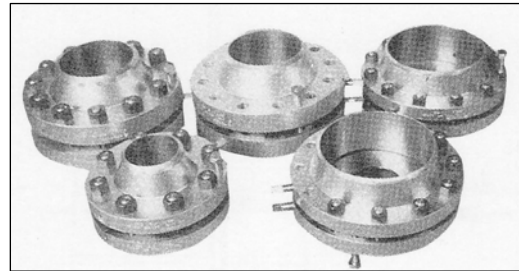

6.2 Specification

- **orifice flange types:**
 - slip-on
 - welding neck
 - ring-joint welding neck
- **nominal diameters:**
 - 25 mm (1") to 500 mm (20")
- **flange rating:**
 - ANSI (or JPI) 150, 300, 600, 900, 1500, 2500 lbs (RF, RTJ)
- **flange material**
 - carbon steel, ASTM 316SS, 316TI, DIN 1.4571
- **materials of bolts and nuts:**
 - stud bolts: A193-B7, B8, etc.
 - nuts: A194-2H, 8, etc.
 - jack bolts and nuts: A193-B7, B8 etc.
- **gaskets:**
 - sheet gaskets 1.5 mm
 - spiral wounded gasket 4.5mm
- **pipng connection method:**
 - ANSI and JPI: butt welding type (welded neck)

6.3 Flange ratings and facings:

Mounting	Standard	Pressure ratings/ facing
Slip-on	ANSI	Class 150 and 300 (RF)
Welding neck	ANSI	Class 150, 300, 600 and 900(RF)
	ANSI	Class 150, 300, 600, 900 and 1500 ring-joint (RJ)
	ANSI	Class 150, 300, 600, 900, 1500 and 2500 (RF, RTJ)

6.4 Types

- Slip-on flanges

The slip-on flange has a low hub because the pipe slips into the flange prior to welding. It is welded both inside and outside to provide sufficient strength and prevent leakage. Slip-on flanges are all bored slightly larger than the O.D. of the matching pipe. They are preferred over welding neck flanges by many users due to their lower initial cost, but final installation cost is probably not much less than that of the welding neck flange because of the additional welding involved.

- Socket welding flanges

The socket welding flange is similar to the slip-on flange except it has a bore and a counter bore dimension. The counter bore is slightly larger than O.D. of the matching pipe, allowing the pipe to be inserted into the flange similar to a slip-on flange. The diameter of the smaller bore is the same as the I.D. of the matching pipe. A restriction is built into the bottom of the bore which sets as a shoulder for the pipe to rest on. This eliminates any restriction in the flow when using a socket welding flange.

- Welding neck flanges

The welding neck flange is normally referred to as the "high hub" flange. It is designed to transfer stresses to the pipe, thereby reducing high stress concentrations at the base of the flange. The welding neck flange is the best designed butt-welded flange of those currently available because of its inherent structural value. It is expensive because of the design.

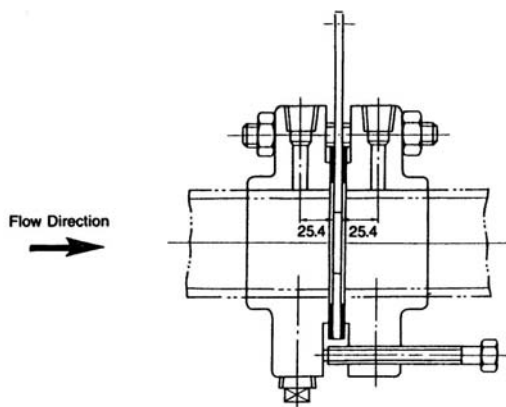

Fig 7: SO-RF

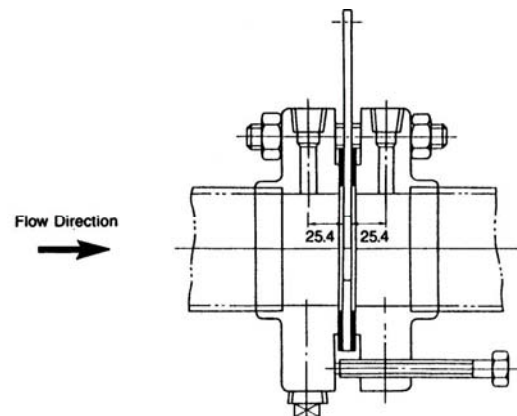

Fig 8: SW

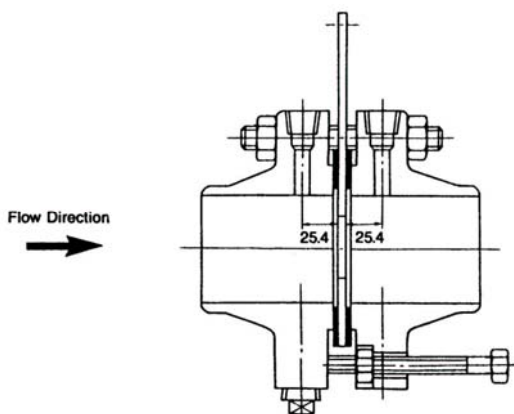

Fig 9: WN-RF

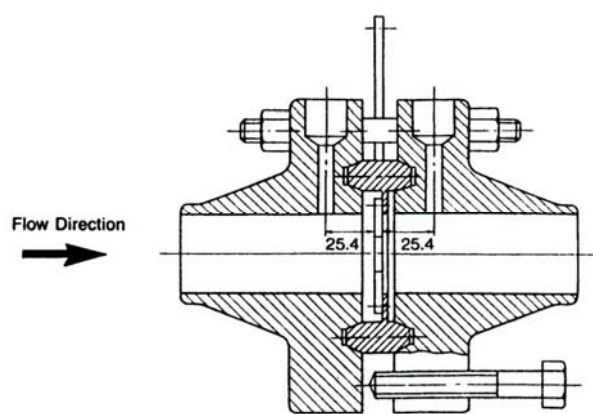

Fig 10: WN-RJ

6.5 Orifice flange dimensions

- class 300 orifice flanges

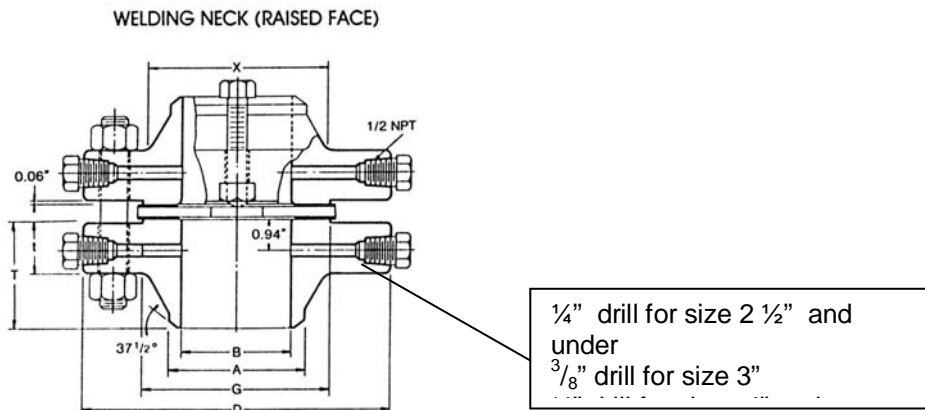

fig.

ANSI B16.36 forged flanges

dimensions in inches

Nominal pipe size	Outside diam. of flange D	Thickness of flange t Raised face	Diam. of			Length thru hub T		Bore B	
			Hub at base X	Raised face G	Hub at bevel A	Welding neck Raised face	Slip-on & threaded Raised face	Welding neck	Slip-on
1	4.88	1.50	2.12	2.00	1.32	3.25	1.81	1.05	1.36
1 1/4	5.25	1.50	2.50	2.50	1.66	3.31	1.88	1.38	1.70
1 1/2	6.12	1.50	2.75	2.88	1.90	3.38	1.88	1.61	1.95
2	6.50	1.50	3.31	3.62	2.38	3.38	1.94	2.07	2.44
2 1/2	7.50	1.50	3.94	4.12	2.88	3.50	2.00	2.47	2.94
3	8.25	1.50	4.62	5.00	3.50	3.50	2.06	3.07	3.57
4	10.00	1.50	5.75	6.19	4.50	3.62	2.12	4.03	4.57
5	11.00	1.50	7.00	7.31	5.56	3.94	2.12	5.05	5.66
6	12.50	1.50	8.12	8.50	6.63	4.00	2.12	6.07	6.72
8	15.00	1.62	10.25	10.62	8.63	4.38	2.44	7.98	8.72
10	17.50	1.88	12.62	12.75	10.75	4.62	2.62	10.02	10.88
12	20.50	2.00	14.75	15.00	12.75	5.12	2.88	12.00	12.88
14	23.00	2.12	16.75	16.25	14.00	5.62	3.00	13.25	14.14
16	25.50	2.25	19.00	18.50	16.00	5.75	3.25	15.25	16.16
18	28.00	2.38	21.00	21.00	18.00	6.25	3.50	17.25	18.18
20	30.50	2.50	23.12	23.00	20.00	6.38	3.75	19.25	20.20
24	36.00	2.75	27.62	27.25	24.00	6.62	4.19	23.25	24.25

Notes:

- (1) for the bore "B" of welding neck flanges other than standard wall thickness ask customer
- (2) Class 300 WN flanges of size 24" and smaller will be bored to match Standard Wall Pipe unless otherwise specified.
- (3) Class 300 orifice flanges will be furnished with 0.06" raised face, which is included in 'Thickness' t and 'length through Hub' T.
- (4) Bolt lengths for raised face flanges include allowance for orifice and gasket thickness of 0.25" for sizes 4-12 and 0.38" for sizes 14-24.

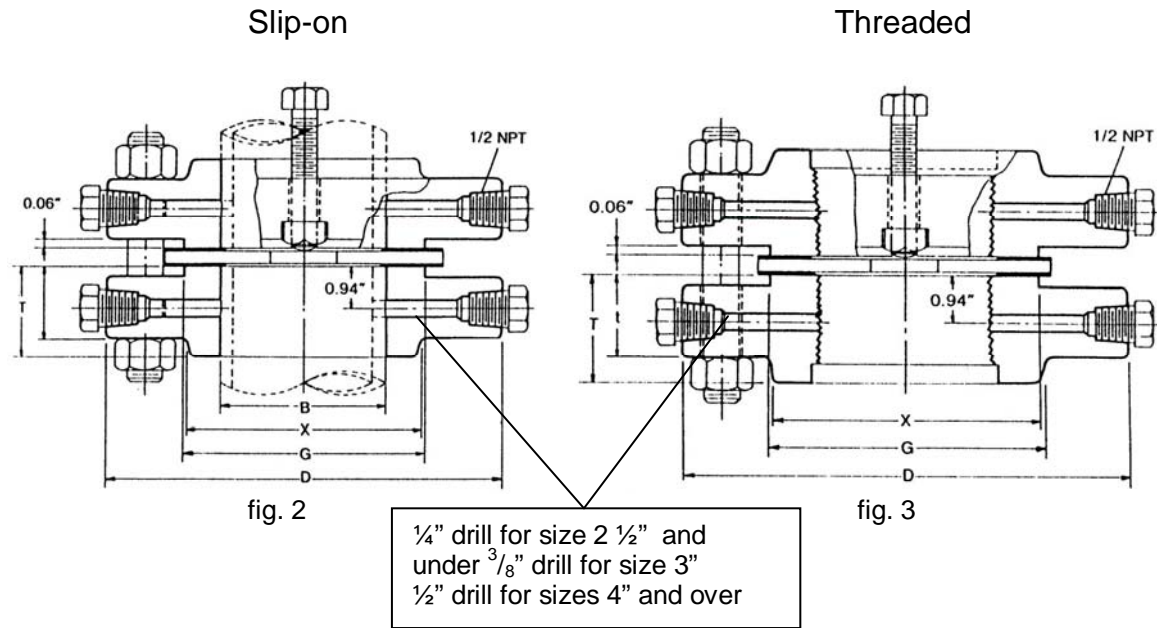

dimensions in inches

Pitch diam. of ring and groove	Ring number	Depth of jack screw slot	Jack screw size	Drilling template					Nominal pipe size
				Diam. of bolts circle	Number of bolts	Diam. of stud bolts	Diam. of bolt holes	Length of stud bolts	
P		Raised face	Raised face					Raised face	
2.000	R16	0.38	Jack screw sizes for 1" thru 24" are those as shown for length and diameter of bolts	3.50	4	5/8	0.69	5.50	1
2.375	R18	0.38		3.88	4	5/8	0.69	6.00	1 1/4
2.688	R20	0.50		4.50	4	3/4	0.88	6.00	1 1/2
3.250	R23	0.38		5.00	8	5/8	0.69	6.00	2
4.000	R26	0.50		5.88	8	3/4	0.88	6.00	2 1/2
4.875	R31	0.50		6.62	8	3/4	0.88	6.00	3
5.875	R37	0.50		7.88	8	3/4	0.88	6.00	4
7.125	R41	0.50		9.25	8	3/4	0.88	6.00	5
8.312	R45	0.50		10.62	12	3/4	0.88	6.00	6
10.625	R49	0.62		13.00	12	1/8	1.00	5.25	8
12.750	R53	0.75		15.25	16	1	1.12	6.50	10
15.000	R57	0.88		17.75	16	1 1/8	1.25	7.00	12
16.500	R61	0.88		20.25	20	1 1/8	1.25	7.25	14
18.500	R65	1.00		22.50	20	1 1/4	1.38	7.75	16
21.000	R69	1.00		24.75	24	1 1/4	1.38	8.00	18
23.000	R73	1.00		27.00	24	1 1/4	1.38	8.50	20
27.250	R77	1.25		32.00	24	1 1/2	1.62	9.50	24

(5) unless otherwise specified, unions of 1" thru 24" furnished with carbon steel regular square headed bolts with hex nuts.

- class 600 orifice flanges

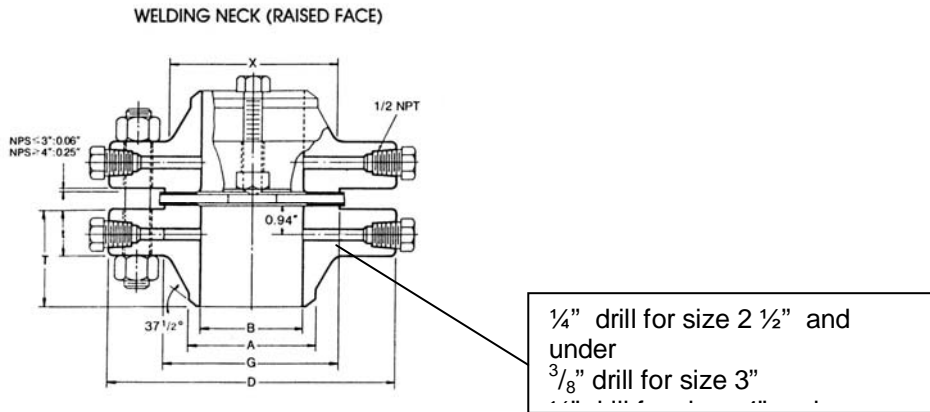

fig. 4

ANSI B16.36 forged flanges

dimensions in inches

Nominal pipe size	Outside diam. of flange	Thickness of flange t		Diam. of	Diam. of	Diam. of	Length thru hub T				Bore B	
				Hub at base	Raised face	Hub at bevel	Welding neck		Slip-on & threaded		Welding neck	Slip-on
				X	G	A	Raised face	Ring joint	Raised face	Ring joint		
1	4.88	1.50	1.25	2.12	2.00	1.32	3.25	3.00	1.88	1.62	See note (1) To be specified by purchaser	1.36
1 ¼	5.25	1.50	1.25	2.50	2.50	1.66	3.31	3.06	1.81	1.56		1.70
1 ½	6.12	1.50	1.25	2.75	2.88	1.90	3.38	3.12	1.88	1.62		1.95
2	6.50	1.50	1.25	3.31	3.62	2.38	3.38	3.12	1.94	1.69		2.44
2 ½	7.50	1.50	1.25	3.94	4.12	2.88	3.50	3.25	2.00	1.75		2.94
3	8.25	1.50	1.25	4.62	5.00	3.50	3.50	3.25	2.06	1.81		3.57
4	10.75	1.50	1.50	6.00	6.19	4.50	4.00	4.00	2.12	2.12		4.57
5	13.00	1.75	1.75	7.44	7.31	5.56	4.50	4.50	2.28	2.38		5.66
6	14.00	1.88	1.88	8.75	8.50	6.63	4.62	4.62	2.62	2.62		6.72
8	16.50	2.19	2.19	10.75	10.62	8.63	5.25	5.25	3.00	3.00		8.72
10	20.00	2.50	2.50	13.50	12.75	10.75	6.00	6.00	3.38	3.38		10.88
12	22.00	2.62	2.62	15.75	15.00	12.75	6.12	6.12	3.62	3.62		12.88
14	23.75	2.75	2.75	17.00	16.25	14.00	6.50	6.50				
16	27.00	3.00	3.00	19.50	18.50	16.00	7.00	7.00				
18	29.25	3.25	3.25	21.50	21.00	18.00	7.25	7.25				
20	32.00	3.50	3.50	24.00	23.00	20.00	7.50	7.50				
24	37.00	4.00	4.00	28.25	27.25	24.00	8.00	8.00				

Notes:

- (1) For the inside diameter of pipes (corresponding to 'Bore' B of welding neck flanges).
- (2) Class 600 flanges of sizes 3" and smaller will be furnished with 0.06" raised face, which is included in 'Thickness' t and 'Length through 'Hub' T. The 0.25" raised face for sizes 4" and larger is not included in t and T.
- (3) Each union includes two carbon steel jack screw bolts with hex nuts.
- (4) Bolt lengths for raised face flanges include allowance for orifice and gasket thickness of 0.62" for sizes 4-10, 0.75" for sizes 12-18 and 0.88" for size 20.

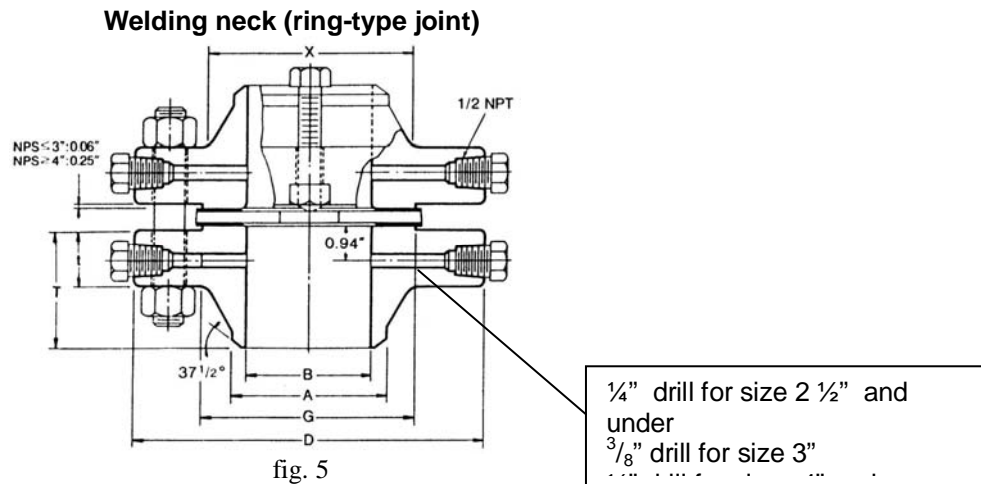

dimensions in inches

Pitch diam. of ring and groove P	Ring number	Depth of jack screw slot		Jack screw size		Drilling template						Nominal pipe size
		Raised face	Ring joint	Raised face	Ring joint	Diam. of bolts circle	Number of bolts	Diam. of stud bolts	Diam. of bolt holes	Length of stud bolts		
										Raised face	Ring joint	
2.000	R16	0.38	0.25	5/8x4.0	5/8x4.75	3.50	4	5/8	0.69	5.00	5.75	1
2.375	R18	0.38	0.25	5/8x4.0	5/8x4.75	3.88	4	5/8	0.69	5.00	5.75	1 1/4
2.688	R20	0.50	0.25	3/4x4.25	3/4x5.00	4.50	4	3/4	0.81	5.25	6.00	1 1/2
3.250	R23	0.38	0.25	5/8x4.0	5/8x4.75	5.00	8	5/8	0.69	5.00	6.00	2
4.000	R26	0.50	0.25	3/4x4.25	3/4x5.00	5.88	8	3/4	0.81	5.25	6.25	2 1/2
4.875	R31	0.50	0.25	3/4x4.25	3/4x5.00	6.62	8	3/4	0.81	5.25	6.25	3
5.875	R37	0.25	0.62	5/8x3.0	5/8x4.00	8.50	8	3/4	1.00	6.00	6.50	4
7.125	R41	0.25	0.62	3/4x3.5	3/4x4.50	10.50	8	1	1.12	5.50	7.00	5
8.312	R45	0.50	0.88	1x4.0	1x4.50	11.50	12	1	1.12	7.00	7.50	6
10.625	R49	0.50	0.88	1x4.0	1x4.75	13.75	12	1 1/8	1.25	7.75	8.25	8
12.750	R53	0.50	0.88	1x4.0	1x5.00	17.00	16	1 1/4	1.38	8.75	9.25	10
15.000	R57	0.50	0.88	1x4.5	1x5.00	19.25	16	1 1/4	1.38	9.00	9.50	12
16.500	R61	0.50	0.88	1x5.0	1x5.50	20.75	20	1 3/8	1.50	9.50	10.00	14
18.500	R65	0.50	0.88	1x5.0	1x5.50	23.75	20	1 1/2	1.62	10.25	10.75	16
21.000	R69	0.50	0.88	1x5.0	1x5.75	25.75	24	1 5/8	1.75	11.00	11.50	18
23.000	R73	0.50	0.88	1x6.0	1x6.25	28.50	24	1 5/8	1.75	11.75	12.50	20
27.250	R77	0.50	0.88	1x6.0	1x7.00	33.00	24	1 5/8	2.00	13.25	13.50	24

Notes:

(5) Unless otherwise specified, raised face unions are furnished with alloy bolt studs per ASTM A 193 Grade B7

With heavy series hex nuts ASTM class 2H.

(6) On ring joint flanges a groove depth 0.375" and less, the distance from the center line of the tap hole to the flange face is 0.750". When the depth of groove is 0.438" or greater, changes in drill size or method of drilling are necessary.

- class 900~1500 orifice flanges

welding neck (raised face)

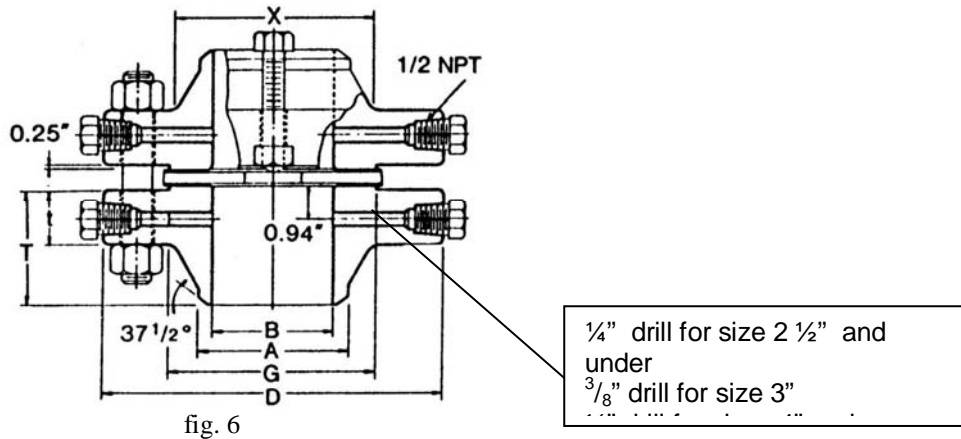

fig. 6

ANSI B16.36 forged flanges

dimensions in inches

Nominal pipe size	Outside diam. of flange	Thickness of flange t		Diam. of	Diam. of	Diam. of	Length thru hub T				Bore B			
				Hub at base	Raised face	Hub at bevel	Welding neck		Slip-on & threaded		Welding neck	Slip-on		
		D	Raised face	Ring joint	X	G	A	Raised face	Ring joint	Raised face			Ring joint	
CLASS 900														
3	9.50	1.50	1.50	5.00	5.00	3.50	4.00	4.00	2.12	2.12	To be specified by purchaser	3.57		
4	11.50	1.75	1.75	6.25	6.19	4.50	4.50	4.50	2.75	2.75		4.57		
5	13.75	2.00	2.00	7.50	7.31	5.56	5.00	5.00	3.12	3.12		5.66		
6	15.00	2.19	2.19	9.25	8.50	6.63	5.50	5.50	3.38	3.38		6.72		
8	18.50	2.50	2.50	11.75	10.62	8.63	6.38	6.38	4.00	4.00		8.72		
10	21.50	2.75	2.75	14.50	12.75	10.75	7.25	7.25	4.25	4.25		10.88		
12	24.00	3.12	3.12	16.50	15.00	12.75	7.88	7.88	4.62	4.62		12.88		
14	25.25	3.38		17.75	16.25	14.00	8.28							
16	27.75	3.50		20.00	18.50	16.00	8.50							
18	31.00	4.00		22.25	21.00	18.00	9.00							
20	33.75	4.25		24.50	23.00	20.00	9.75							
24	41.00	5.50		29.50	27.25	24.00	11.50							
CLASS 1500														
1	5.88	1.50	1.50	2.06	2.00	1.32	3.25	3.25	1.88	1.75	To be specified by purchaser	1.36		
1 1/4	6.25	1.28	1.28	2.50	2.50	1.66	2.88	2.88	1.88	1.75		1.70		
1 1/2	7.00	1.50	1.50	2.75	2.88	1.90	3.50	3.50	1.88	1.75		1.95		
2	8.50	1.50	1.50	4.12	3.62	2.38	4.00	4.00	2.25	2.25		2.44		
2 1/2	9.62	1.62	1.62	4.88	4.12	2.88	4.12	4.12	2.50	2.50		2.94		
3	10.50	1.88	1.88	5.25	5.00	3.50	4.62	4.62	2.88	2.88		3.57		
4	12.25	2.12	2.12	6.38	6.19	4.50	4.88	4.88	3.56	3.56		4.57		
5	14.75	2.88	2.88	7.75	7.31	5.56	6.12	6.12	4.12	4.12		5.66		
6	15.50	3.25	3.25	9.00	8.50	6.63	6.75	6.75	4.69	4.69		6.72		
8	19.00	3.62	3.62	11.50	10.62	8.63	8.38	8.38	5.62	5.62		8.72		
10	23.00	4.25	4.25	14.50	12.75	10.75	10.00	10.00	6.25	6.25		10.88		
12	26.50	4.88	4.88	17.75	15.00	12.75	11.12	11.12	7.12	7.12		12.88		
14	29.50	5.25		19.50	16.25	14.00	11.75							
16	32.50	5.75		21.75	18.50	16.00	12.25							
18	36.00	6.38		23.50	21.00	18.00	12.88							
20	38.75	7.00		25.25	23.00	20.00	14.00							
24	46.00	8.00		30.00	27.25	24.00	16.00							

Notes:

- (1) For the inside diameter of pipes (corresponding to 'Bore' B of welding neck flanges)
- (2) Class 900 dimensions of size 1" through 2 1/2" are the same as for Class 1500.
- (3) Class 900 and 1500 is not included in 'thickness' t and 'length through hub' T.
- (4) Each union includes two carbon steel jack screw bolts with hex nuts.

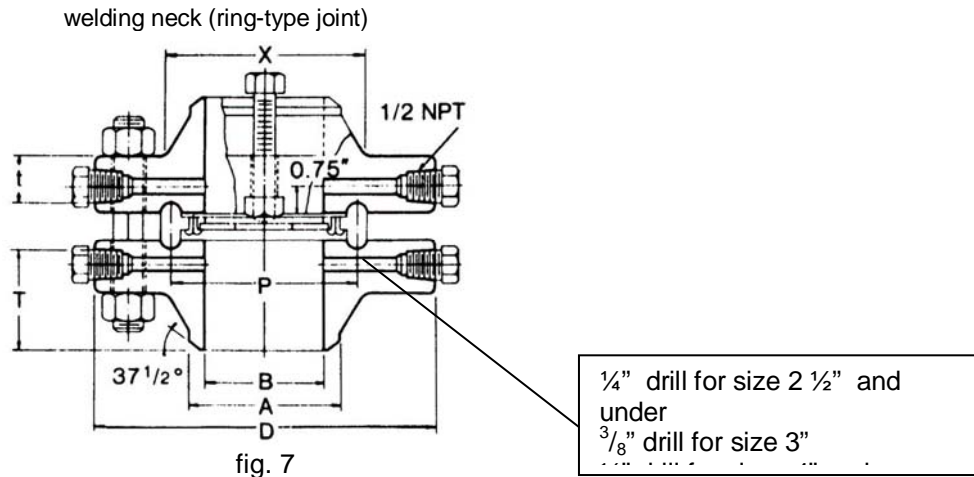

dimensions in inches

Pitch diam. of ring and groove P	Ring number	Depth of jack screw slot		Jack screw size		Drilling template						Nominal pipe size
		Raised face	Ring joint	Raised face	Ring joint	Diam. of bolts circle	Number of bolts	Diam. of stud bolts	Diam. of bolt holes	Length of stud bolts		
										Raised face	Ring joint	
CLASS 900												
4.875	R31	0.38	0.62	3/4x3.5	3/4x4.00	7.50	8	1/8	1.00	6.00	6.50	3
5.875	R37	0.38	0.62	3/4x3.5	3/4x4.50	9.25	8	1 1/8	1.25	7.00	7.50	4
7.125	R41	0.38	0.62	3/4x3.5	3/4x4.50	11.00	8	1 1/4	1.38	7.50	8.00	5
8.312	R45	0.62	0.88	1x4.5	1x4.75	12.50	12	1 1/8	1.25	7.75	8.25	6
10.625	R49	0.62	0.88	1x4.5	1x5.00	15.50	12	1 3/8	1.50	9.00	9.50	8
12.750	R53	0.62	0.88	1x4.5	1x5.25	18.50	16	1 3/8	1.50	9.50	10.00	10
15.000	R57	0.62	0.88	1x4.5	1x5.50	21.00	20	1 3/8	1.50	10.25	10.75	12
						22.00	20	1 1/2	1.62	11.00		14
						24.25	20	1 5/8	1.75	11.50		16
						27.00	20	1 7/8	2.00	13.00		18
						29.50	20	2	2.12	14.00		20
						35.50	20	2 1/2	2.62	17.50		24
CLASS 1500												
2.000	R16	0.25	0.50	5/8x3.0	5/8x3.50	4.00	4	1/8	1.00	6.00	6.25	1
2.375	R18	0.25	0.50	5/8x3.0	5/8x3.50	4.38	4	1/8	1.00	5.50	5.75	1 1/4
2.688	R20	0.25	0.50	5/8x3.0	5/8x3.50	4.88	4	1	1.12	6.25	6.50	1 1/2
3.750	R24	0.25	0.50	5/8x3.0	5/8x4.00	6.50	8	1/8	1.00	6.00	6.50	2
4.250	R27	0.25	0.50	5/8x3.0	5/8x4.00	7.50	8	1	1.12	6.50	7.00	2 1/2
5.375	R35	0.38	0.62	5/8x3.5	3/4x4.50	8.00	8	1 1/8	1.25	7.25	7.75	3
6.375	R39	0.38	0.62	3/4x3.5	3/4x4.50	9.50	8	1 1/4	1.38	8.00	8.50	4
7.625	R44	0.38	0.62	3/4x3.5	3/4x4.50	11.50	8	1 1/2	1.62	9.75	10.25	5
8.312	R46	0.62	0.88	1x6.0	1x6.50	12.50	12	1 3/8	1.50	10.50	11.00	6
10.625	R50	0.62	0.88	1x6.5	1x6.50	15.50	12	1 5/8	1.75	11.75	12.50	8
12.750	R54	0.62	0.88	1x6.5	1x7.00	19.00	12	1 7/8	2.00	13.50	14.25	10
15.000	R58	0.62	0.88	1x6.5	1x8.00	22.50	16	2	2.12	15.00	1 5/8	12
						25.00	16	2 1/4	2.38	16.25		14
						27.75	16	2 1/2	2.62	17.75		16
						30.50	16	2 3/4	2.88	19.75		18
						32.75	16	3	3.12	21.50		20
						39.00	16	3 1/2	3.62	24.5		24

Notes:

- (5) Unless otherwise specified, raised face unions are furnished with alloy bolt studs per ASTM A 193 Grade B7 with heavy series hex nuts ASTM class 2H.
- (6) On ring joint flanges a groove depth 0.375" and less, the distance from the center line of the tap hole to the flange face is 0.750". When the depth of groove is 0.438" or greater, changes in drill size or method of drilling are necessary.
- (7) Bolt lengths for raised face flanges include allowance for orifice and gasket thickness of 0.25" for sizes 4-12 and 0.38" for sizes 14-24. Bolt lengths for ring type joint flanges include allowance of 0.62" for sizes 4-10, 0.75" for sizes 12-18 and 0.88" for size 20.

Class 2500 orifice flanges

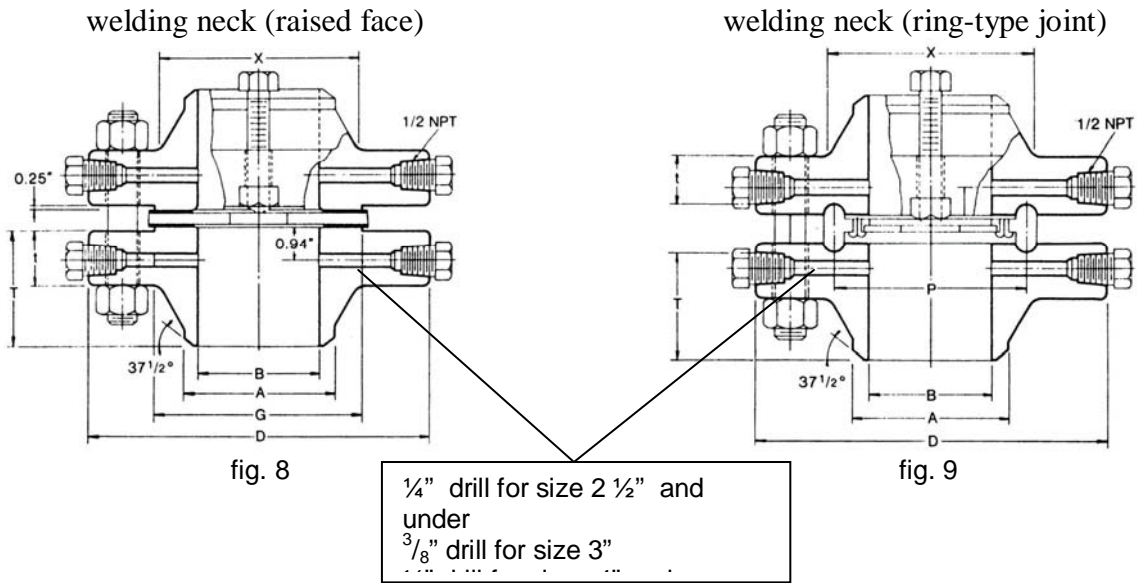

ANSI B16.36 forged flanges

dimensions in inches

Nom. Pipe size	O.D. of Flange face	O.D. of raised flange	THK's of Hub min.	Length thru	Diam. of hub	Diam. of hub at bevel	Bore	Ring type joint	Ring number	Drilling template				Length of stud bolts	
										Diam. of bolt circle	Number of holes	Diam. of holes	Diam. of bolts	Raised face	Ring joint
	D	G	t	T	X	A	B	P							
1	6.25	2.00	1.50	3.62	2.25	1.32	See note (1) to be spec. by purchaser	2.375	R18	4.25	4	1.00	7/8	6.00	6.25
1 1/2	8.00	2.88	1.75	4.38	3.12	1.90		3.250	R23	5.75	4	1.25	1 1/8	7.00	7.50
2	9.25	3.62	2.00	5.00	3.75	2.38		4.000	R26	6.75	8	1.12	1	7.25	7.75
2 1/2	10.50	4.12	2.25	5.62	4.50	2.88		4.375	R28	7.75	8	1.25	1 1/8	8.00	8.50
3	12.00	5.00	2.62	6.62	5.25	3.50		5.000	R32	9.00	8	1.38	1 1/4	9.00	9.50
4	14.00	6.19	3.00	7.50	6.50	4.50				10.75	8	1.62	1 1/2	10.25	
6	19.00	8.50	4.25	10.75	9.25	6.63				14.50	8	2.12	2	13.75	
8	21.75	10.62	5.00	12.50	12.00	8.63				17.25	12	2.12	2	15.25	
10	26.50	12.75	6.50	16.50	14.75	10.75				21.25	12	2.62	2 1/2	19.25	
12	30.00	15.00	7.25	18.25	17.38	12.75				24.38	12	2.88	2 3/4	21.25	

Notes:

- (1) For the inside diameter of pipes (corresponding to 'Bore' B of welding neck flange)
- (2) Class 2500 flanges will be furnished with 0.25" raised face, which is not included in 'Thickness' t and 'Length through hub' T
- (3) Each union includes two carbon steel jack screw bolts with hex nuts.
- (4) Unless otherwise specified, raised face unions are furnished with allow bolt studs per ASTM A193 Grade B7 with hex nuts ASTM A194 Class 2H.
- (5) On ring joint flanges having a groove depth 0.375" and less, the distance from the center line of the tap hole to the flange face is 0.750". When the depth of groove is 0.438" or greater, changes in drill size or method of drilling are necessary.
- (6) Class 2500 slip-on flanges are not covered by ANSI B16.5.
- (7) Bolt lengths for raised face flanges include allowance for orifice and gasket thickness of 0.25" for sizes 4-12 and 0.38" for sizes 14-24. Bolt lengths for ring type joint flanges include allowance of 0.62" for sizes 4-10, 0.75" for sizes 12-18 and 0.88" for size 20.

6.5 Ordering codes

Code	Description	
BLS	Throttle devices with flange taps – PN40	
1. Measuring flanges acc. to DIN 19214, flange face Form C		
300	Standard	
2. Flanges		
D	Flange face acc. to DIN	
3. Orifice calculation by Intra		
0	without	
1	with	
4. Documentation		
0	without	
1	Material certificate DIN EN 10204-2.2	
2	Material certificate DIN EN 10204-3.1	
5. Orifice plate material		
1	316L	
2	316Ti	
6. Pressure rating acc. to DIN / flange face		
X	PN40 / Form C	
7. Material gaskets		
A	Klingersil-C4400, 3 mm	
B	Stainless steel/Graphite, 4,5 mm	
8. Bolts & Nuts		
1	A193 B7 / A194 2H – CS	
2	A193 B8 / A194 8M – SS	
9. Connection dimension / material flanges		
A1	DN50	CS
A2		316Ti
B1	DN65	CS
B2		316Ti
C1	DN80	CS
C2		316Ti
D1	DN100	CS
D2		316Ti
E1	DN125	CS
E2		316Ti
F1	DN150	CS
F2		316Ti
G1	DN200	CS
G2		316Ti
H1	DN250	CS
H2		316Ti
J1	DN300	CS
J2		316Ti
K1	DN350	CS
K2		316Ti
L1	DN400	CS
L2		316Ti
M1	DN500	CS
M2		316Ti
N1	DN600	CS
N2		316Ti
P1	DN700	CS
P2		316Ti
Q1	DN800	CS
Q2		316Ti

To be continued on page 23

Code	Description	
BLS	Throttle devices with flange taps – PN64	
	1. Measuring flanges acc. to DIN 19214, flange face Form C	
300	Standard	
	2. Flanges	
D	Flange face acc. to DIN	
	3. Orifice calculation by Intra	
0	without	
1	with	
	4. Documentation	
0	without	
1	Material certificate DIN EN 10204-2.2	
2	Material certificate DIN EN 10204-3.1	
	5. Orifice plate material	
1	316L	
2	316Ti	
	6. Pressure rating acc. to DIN / flange face	
X	PN40 / Form C	
	7. Material gaskets	
A	Klingsil-C4400, 3 mm	
B	Stainless steel/Graphite, 4,5 mm	
	8. Bolts & Nuts	
1	A193 B7 / A194 2H – CS	
2	A193 B8 / A194 8M – SS	
	9. Connection dimension / material flanges	
A1	DN50	CS
A2		316Ti
B1	DN65	CS
B2		316Ti
C1	DN80	CS
C2		316Ti
D1	DN100	CS
D2		316Ti
E1	DN125	CS
E2		316Ti
F1	DN150	CS
F2		316Ti
G1	DN200	CS
G2		316Ti
H1	DN250	CS
H2		316Ti
J1	DN300	CS
J2		316Ti
K1	DN350	CS
K2		316Ti
L1	DN400	CS
L2		316Ti
M1	DN500	CS
M2		316Ti
N1	DN600	CS
N2		316Ti
P1	DN700	CS
P2		316Ti
Q1	DN800	CS
Q2		316Ti

To be continued on page 25

Code	Description	
BLS	Throttle devices with flange taps – PN100	
	1. Measuring flanges acc. to DIN 19214, flange face Form C	
300	Standard	
	2. Flanges	
D	Flange face acc. to DIN	
	3. Orifice calculation by Intra	
0	without	
1	with	
	4. Documentation	
0	without	
1	Material certificate DIN EN 10204-2.2	
2	Material certificate DIN EN 10204-3.1	
	5. Orifice plate material	
1	316L	
2	316Ti	
	6. Pressure rating acc. to DIN / flange face	
X	PN40 / Form C	
	7. Material gaskets	
A	Klingsil-C4400, 3 mm	
B	Stainless steel/Graphite, 4,5 mm	
	8. Bolts & Nuts	
1	A193 B7 / A194 2H – CS	
2	A193 B8 / A194 8M – SS	
	9. Connection dimension / material flanges	
A1	DN50	CS
A2		316Ti
B1	DN65	CS
B2		316Ti
C1	DN80	CS
C2		316Ti
D1	DN100	CS
D2		316Ti
E1	DN125	CS
E2		316Ti
F1	DN150	CS
F2		316Ti
G1	DN200	CS
G2		316Ti
H1	DN250	CS
H2		316Ti
J1	DN300	CS
J2		316Ti
K1	DN350	CS
K2		316Ti
L1	DN400	CS
L2		316Ti
M1	DN500	CS
M2		316Ti
N1	DN600	CS
N2		316Ti
P1	DN700	CS
P2		316Ti
Q1	DN800	CS
Q2		316Ti

To be continued on page 27

Code	Description	
BLS	Throttle devices with flange taps – 150 lbs	
	1. Measuring flanges acc. to ANSI B16.5, 150 lbs	
300	Standard	
	2. Flanges	
D	Flange face acc. to ANSI	
	3. Orifice calculation by Intra	
0	without	
1	with	
	4. Documentation	
0	without	
1	Material certificate DIN EN 10204-2.2	
2	Material certificate DIN EN 10204-3.1	
	5. Orifice plate material	
1	304L	
2	316Ti	
	6. Pressure rating acc. to DIN / flange face	
X	PN40 / Form C	
	7. Material gaskets	
A	Klingsil-C4400, 3 mm	
B	Stainless steel/Graphite, 4,5 mm	
	8. Bolts & Nuts	
1	A193 B7 / A194 2H – CS	
2	A193 B8 / A194 8M – SS	
	9. Connection dimension / material flanges	
A1	2"	A105
A2		316L
B1	2 ½"	A105
B2		316L
C1	3"	A105
C2		316L
D1	4"	A105
D2		316L
E1	5"	A105
E2		316L
F1	6"	A105
F2		316L
G1	8"	A105
G2		316L
H1	10"	A105
H2		316L
J1	12"	A105
J2		316L
K1	14"	A105
K2		316L
L1	16"	A105
L2		316L
M1	20"	A105
M2		316L
N1	24"	A105
N2		316L

To be continued on page 29

Code	Description	
BLS	Throttle devices with flange taps – 300 lbs	
	1. Measuring flanges acc. to ANSI B16.5, 300 lbs	
300	Standard	
	2. Flanges	
D	Flange face acc. to ANSI	
	3. Orifice calculation by Intra	
0	without	
1	with	
	4. Documentation	
0	without	
1	Material certificate DIN EN 10204-2.2	
2	Material certificate DIN EN 10204-3.1	
	5. Orifice plate material	
1	304L	
2	316Ti	
	6. Pressure rating acc. to DIN / flange face	
X	PN40 / Form C	
	7. Material gaskets	
A	Klingsil-C4400, 3 mm	
B	Stainless steel/Graphite, 4,5 mm	
	8. Bolts & Nuts	
1	A193 B7 / A194 2H – CS	
2	A193 B8 / A194 8M – SS	
	9. Connection dimension / material flanges	
A1	2"	A105
A2		316L
B1	2 ½"	A105
B2		316L
C1	3"	A105
C2		316L
D1	4"	A105
D2		316L
E1	5"	A105
E2		316L
F1	6"	A105
F2		316L
G1	8"	A105
G2		316L
H1	10"	A105
H2		316L
J1	12"	A105
J2		316L
K1	14"	A105
K2		316L
L1	16"	A105
L2		316L
M1	20"	A105
M2		316L
N1	24"	A105
N2		316L

To be continued on page 31

Code	Description	
BLS	Throttle devices with flange taps – 600 lbs	
	1. Measuring flanges acc. to ANSI B16.5, 600 lbs	
300	Standard	
	2. Flanges	
D	Flange face acc. to ANSI	
	3. Orifice calculation by Intra	
0	without	
1	with	
	4. Documentation	
0	without	
1	Material certificate DIN EN 10204-2.2	
2	Material certificate DIN EN 10204-3.1	
	5. Orifice plate material	
1	304L	
2	316Ti	
	6. Pressure rating acc. to DIN / flange face	
X	PN40 / Form C	
	7. Material gaskets	
A	Klingsil-C4400, 3 mm	
B	Stainless steel/Graphite, 4,5 mm	
	8. Bolts & Nuts	
1	A193 B7 / A194 2H – CS	
2	A193 B8 / A194 8M – SS	
	9. Connection dimension / material flanges	
A1	2"	A105
A2		316L
B1	2 ½"	A105
B2		316L
C1	3"	A105
C2		316L
D1	4"	A105
D2		316L
E1	5"	A105
E2		316L
F1	6"	A105
F2		316L
G1	8"	A105
G2		316L
H1	10"	A105
H2		316L
J1	12"	A105
J2		316L
K1	14"	A105
K2		316L
L1	16"	A105
L2		316L
M1	20"	A105
M2		316L
N1	24"	A105
N2		316L

To be continued on page 33

Code	Description	
BLS	Throttle devices with flange taps – 900 lbs	
	1. Measuring flanges acc. to ANSI B16.5, 900 lbs	
300	Standard	
	2. Flanges	
D	Flange face acc. to ANSI	
	3. Orifice calculation by Intra	
0	without	
1	with	
	4. Documentation	
0	without	
1	Material certificate DIN EN 10204-2.2	
2	Material certificate DIN EN 10204-3.1	
	5. Orifice plate material	
1	304L	
2	316Ti	
	6. Pressure rating acc. to DIN / flange face	
X	PN40 / Form C	
	7. Material gaskets	
A	Klingsil-C4400, 3 mm	
B	Stainless steel/Graphite, 4,5 mm	
	8. Bolts & Nuts	
1	A193 B7 / A194 2H – CS	
2	A193 B8 / A194 8M – SS	
	9. Connection dimension / material flanges	
A1	2"	A105
A2		316L
B1	2 ½"	A105
B2		316L
C1	3"	A105
C2		316L
D1	4"	A105
D2		316L
E1	5"	A105
E2		316L
F1	6"	A105
F2		316L
G1	8"	A105
G2		316L
H1	10"	A105
H2		316L
J1	12"	A105
J2		316L
K1	14"	A105
K2		316L
L1	16"	A105
L2		316L
M1	20"	A105
M2		316L
N1	24"	A105
N2		316L

To be continued on page 35

Code	Description	
BLS	Throttle devices with flange taps – 1500 lbs	
	1. Measuring flanges acc. to ANSI B16.5, 1500 lbs	
300	Standard	
	2. Flanges	
D	Flange face acc. to ANSI	
	3. Orifice calculation by Intra	
0	without	
1	with	
	4. Documentation	
0	without	
1	Material certificate DIN EN 10204-2.2	
2	Material certificate DIN EN 10204-3.1	
	5. Orifice plate material	
1	304L	
2	316Ti	
	6. Pressure rating acc. to DIN / flange face	
X	PN40 / Form C	
	7. Material gaskets	
A	Klingsil-C4400, 3 mm	
B	Stainless steel/Graphite, 4,5 mm	
	8. Bolts & Nuts	
1	A193 B7 / A194 2H – CS	
2	A193 B8 / A194 8M – SS	
	9. Connection dimension / material flanges	
A1	2"	A105
A2		316L
B1	2 ½"	A105
B2		316L
C1	3"	A105
C2		316L
D1	4"	A105
D2		316L
E1	5"	A105
E2		316L
F1	6"	A105
F2		316L
G1	8"	A105
G2		316L
H1	10"	A105
H2		316L
J1	12"	A105
J2		316L
K1	14"	A105
K2		316L
L1	16"	A105
L2		316L
M1	20"	A105
M2		316L
N1	24"	A105
N2		316L

To be continued on page 37

7 Pressure tap connections

Pressure connection holes in the pipe should be $1/2''$ for 4" and larger lines, $3/8''$ for 3" lines and $1/4''$ for 2" lines. When flange taps are used, insert a drill of the proper size through the connection holes in the flanges and drill through the pipe. When connections in the pipe are used, weld half-couplings to the pipe at the proper locations, insert a drill through them, and drill through the pipe. Round off the edges of the holes slightly to be sure that no burrs remain in the pipe.

◆ Flange taps

Pressure connection holes are located in the flanges 1" upstream and 1" downstream from the corresponding orifice plate faces (see fig. 4 and fig. 5)

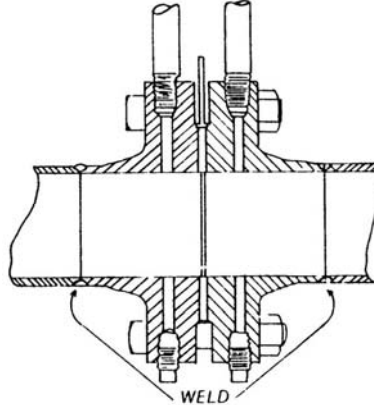

◆ Corner taps

On lines smaller than 2", the orifice flange pipe union shown in fig. 6 is used. The effect is that the pressure taps are right at the orifice plate.

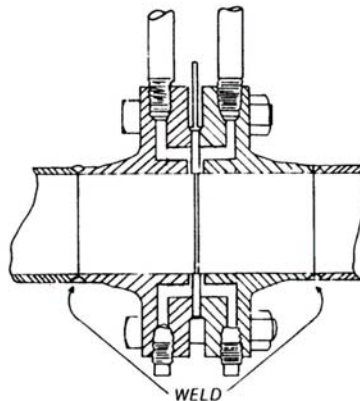

◆ 2,5 D and 8 D taps, also called full-flow pipe taps

Connections are installed 2,5 pipe-diameters upstream from the upstream face of the orifice plate and 8 pipe diameters downstream from the upstream face of the orifice plate.

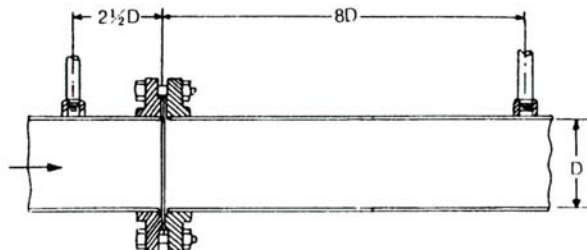

◆ **1 D and 0,5 D taps, also called radius taps**

This type of connection is modification of and has largely replaced the Vena Contracta taps. It yields equally accurate results and has the advantage that the downstream connection is easier to locate. The upstream connection should be at 1 D above the upstream face of the orifice plate, but location of the upstream connection anywhere between 0,5 and 2 D introduces only negligible error. The downstream connection is located 0,5 C from the upstream face of the orifice plate.

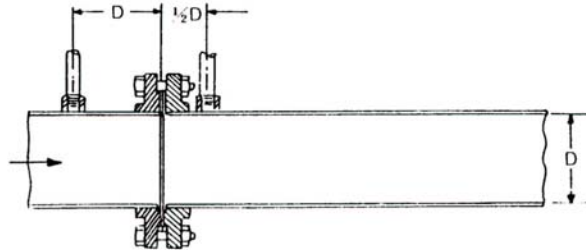

◆ **“Vena Contracta” taps**

The upstream connection (dimension M) may be located anywhere between 0,5 and 2 pipe diameters above the upstream face of the orifice plate. The downstream connection (dimension N) is made at the point of maximum flow constriction and is given by the table below:

Orifice to pipe Diameter ratio d/D	Location of downstream Pressure Tap (N) (pipe diameters)		
	min	mean	max.
	0,2	0,37	0,85
0,3	0,44	0,80	1,15
0,4	0,47	0,73	1,00
0,5	0,47	0,66	0,84
0,6	0,42	0,57	0,70
0,7	0,35	0,45	0,55
0,8	0,25	0,33	0,41

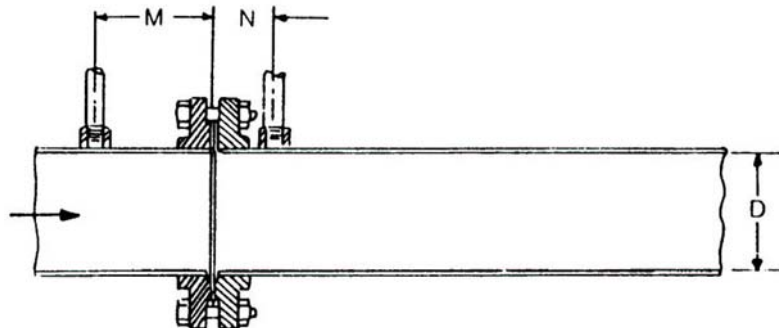

8 Orifice meter runs, type: MBL-500

8.1 Description

Orifice meter runs are used for measuring the flow at higher accuracy.

The orifice meter runs are therefore, not the ones simply weld pipes to upstream and downstream sides or an orifice assembly, but the ones welding smaller inside diameter pipes to smaller diameter of flanges, then, finish inside diameter or the pipe / flange assembly by boring or honing to the specified dimensions with the required tolerances and surface roughness (see fig. 20 and fig. 21).

8.2 Type and drawing

- ◆ Orifice meter run (both sides fanged):

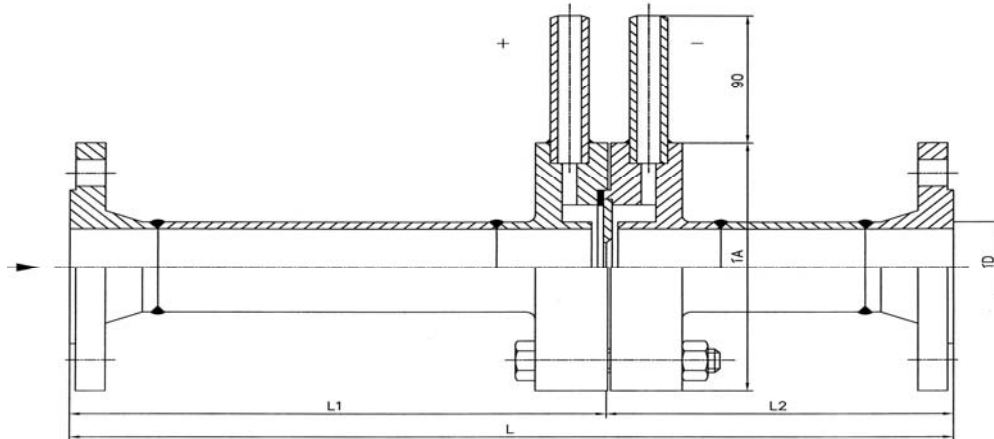

fig. 20

- ◆ Orifice meter run (butt welding ends)

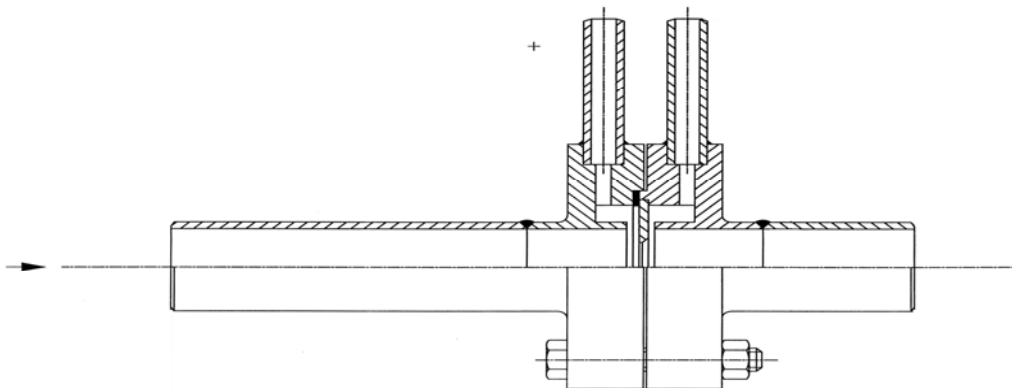

Fig. 21

8.3 Order Codes

Code	Description			
MBL500	Measuring section with integral concentric square edge orifice plate (material orifice plate: 316L) with flange connection acc. ANSI Upstream length: 250 mm Downstream length: 200 mm			
	Flange face			
	SA	RF – 125 RAAH	150 lbs	
	SJ	RTJ		
	Materials of construction			
		Flange	Body	Size and rating
	R12	A105	A106A234WPA	1/2" 150 lbs
	SR12	A105	316L	
	S12	316L	316L	
	R13	A105	A106A234WPA	3/4" 150 lbs
	SR13	A105	316L	
	S13	316L	316L	
	R14	A105	A106A234WPA	1" 150 lbs
	SR14	A105	316L	
	S14	316L	316L	
	R15	A105	A106A234WPA	1 1/2" 150 lbs
	SR15	A105	316L	
	S15	316L	316L	
	R16	A105	A106A234WPA	2" 150 lbs
	SR16	A105	316L	
	S16	316L	316L	
	Flange face			
	SA	RF – 125 RAAH	300 lbs	
	SJ	RTJ		
	Materials of construction			
		Flange	Body	Size and rating
R17	A105	A106A234WPA	1/2" 300 lbs	
SR17	A105	316L		
S17	316L	316L		
R18	A105	A106A234WPA	3/4" 300 lbs	
SR18	A105	316L		
S18	316L	316L		
R19	A105	A106A234WPA	1" 300 lbs	
SR19	A105	316L		
S19	316L	316L		
R20	A105	A106A234WPA	1 1/2" 300 lbs	
SR20	A105	316L		
S20	316L	316L		
R21	A105	A106A234WPA	2" 300 lbs	
SR21	A105	316L		
S21	316L	316L		
Flange face				
SA	RF – 125 RAAH	600 lbs		
SJ	RTJ			
Materials of construction				
	Flange	Body	Size and rating	
R22	A105	A106A234WPA	1/2" 600 lbs	
SR22	A105	316L		
S22	316L	316L		
R23	A105	A106A234WPA	3/4" 600 lbs	
SR23	A105	316L		
S23	316L	316L		
R24	A105	A106A234WPA	1" 600 lbs	
SR24	A105	316L		
S24	316L	316L		
R25	A105	A106A234WPA	1 1/2" 600 lbs	
SR25	A105	316L		
S25	316L	316L		
R26	A105	A106A234WPA	2" 600 lbs	
SR26	A105	316L		
S26	316L	316L		
MBL500				

To be continued on page 42

Continuation page 41

MBL500		
---------------	--	--

Flange face			
SA	RF – 125 RAAH	1500 lbs	
SJ	RTJ		
Materials of construction			
	Flange	Body	Size and rating
R27	A105	A106A234WPA	1/2" 1500 lbs
SR27	A105	316L	
S27	316L	316L	
R28	A105	A106A234WPA	3/4" 1500 lbs
SR28	A105	316L	
S28	316L	316L	
R29	A105	A106A234WPA	1" 1500 lbs
SR29	A105	316L	
S29	316L	316L	
R30	A105	A106A234WPA	1 1/2" 1500 lbs
SR30	A105	316L	
S30	316L	316L	
R31	A105	A106A234WPA	2" 1500 lbs
SR31	A105	316L	
S31	316L	316L	
Flange face			
SA	RF – 125 RAAH	2500 lbs	
SJ	RTJ		
Materials of construction			
	Flange	Body	Size and rating
R32	A105	A106A234WPA	1/2" 2500 lbs
SR32	A105	316L	
S32	316L	316L	
R33	A105	A106A234WPA	3/4" 2500 lbs
SR33	A105	316L	
S33	316L	316L	
R34	A105	A106A234WPA	1" 2500 lbs
SR34	A105	316L	
S34	316L	316L	
R35	A105	A106A234WPA	1 1/2" 2500 lbs
SR35	A105	316L	
S35	316L	316L	
R36	A105	A106A234WPA	2" 2500 lbs
SR36	A105	316L	
S36	316L	316L	
Flange plate to direct mount a manifold			
0	without		
A06	Flange plate for 3-way-manifold, material 316Ti		
A80	2 off shut off valve type A7-2PT-SZ14x4,5, PN400, complete with flange plate for 3-way-manifold		
Instrument connection			
0	without		
A66	direct mount, with 3-way-manifold, PN400, housing: 316L / packing: PTFE (only with A06 or A80)		

MBL500				
---------------	--	--	--	--

Besides the products covered by this brochure, Intra-Automation GmbH also manufactures other high-quality and high precision instruments for industrial measurement tasks. For more information, please contact us (contact details on the backside of this brochure).

Flow measurement



Itabar®-Flow Sensor



IntraSonic IS210 Ultrasonic Flow Meter

Level measurement



ITA-mag. Level Gauge



MAGLINK Level Indicator

Other Measurement Tasks:



DigiFlow Flow and Level Computers



IntraCon Digital Controllers



IntraDigit Digital Indicators / Meters



INTRA-AUTOMATION

MESS- UND REGELINSTRUMENTE / MEASUREMENT AND CONTROL



TÜVRheinland®
CERT
ISO 9001

International Headquarters:

Intra-Automation GmbH
Otto-Hahn-Str. 20
41515 Grevenbroich
GERMANY

☎ +49 – (0) 21 81 / 7 56 65-0

☎ +49 – (0) 21 81 / 6 44 92

✉ info@intra-automation.de

🌐 www.intra-automation.com

Sales Office for the BENELUX:

B.V. Intra-Automation HTP
PO Box 10
4730 AA Oudenbosch
THE NETHERLANDS

☎ +31 – (0)165 – 32 22 01

☎ +31 – (0)165 – 32 29 70

✉ info@intra-automation.nl