



Zertifiziertes  
QM-System  
DIN EN ISO 9001  
Zertifikat-Nr. 01017

## Vortex Flowmeter Compact

for low viscosity liquids



measuring  
•  
monitoring  
•  
analysing

### DVZ



- Range:  
0.5-4.5 ... 10-100 l/min
- Accuracy:  
±2.5% of full scale
- $p_{max}$ : 20 bar;  $t_{max}$ : 80 °C
- Connections:  
G 1/4 ... G 1, 1/4" NPT ... 1" NPT
- Connection material:  
brass or stainless steel
- Output: switching output,  
frequency output,  
analogue output
- Compact electronics with  
digital display

GS



KOBOLD companies worldwide:

ARGENTINA, AUSTRALIA, AUSTRIA, BELGIUM, BULGARIA, CANADA, CHILE, CHINA, COLOMBIA, CZECHIA, EGYPT, FRANCE, GERMANY, GREAT BRITAIN, HUNGARY, INDIA, INDONESIA, ITALY, MALAYSIA, MEXICO, NETHERLANDS, PERU, POLAND, REPUBLIC OF KOREA, ROMANIA, SINGAPORE, SPAIN, SWITZERLAND, TAIWAN, THAILAND, TUNISIA, TURKEY, USA, VIETNAM

KOBOLD Messring GmbH  
Nordring 22-24  
D-65719 Hofheim/Ts.  
Head Office:  
+49(0)6192 299-0  
+49(0)6192 23398  
info.de@kobold.com  
www.kobold.com



DVZ-...S300

DVZ-...F300  
DVZ-...L303  
DVZ-...L343

DVZ-...L443

DVZ-...L443  
(usage with AUF-3000)

DVZ-...C3...  
(compact electronics)

**Description**

The compact KOBOLD Vortex flow meter Model DVZ is used for measuring and monitoring smaller and medium-sized flow of low viscosity, water-like liquids in pipes. The device works using the vortex principle, making it virtually maintenancefree. This involves the installation of a sharp-edged object (the vortex generator) in the flow duct. Vortices are created behind the object whose frequency is proportional to the velocity of flow of the liquid. The flow volume can be determined with a very great degree of accuracy by measuring the vortex frequency. This achieves a very high linearity over the whole measuring range.

The device can be fitted with switching, frequency or analogue outputs. There is also an optional compact electronics package that includes a digital display, and both a switching and analogue output. Dosing and metering electronics are currently being developed.

**Areas of Application**

- Monitoring the flow of low viscosity liquids
- Measuring of aggressive, high-purity or salty solutions
- Unsuitable for abrasive media or media containing a large proportion of fibres

**Technical Details**

Measurement process: vortex principle  
 Mounting position: any, flow in direction of arrow  
 Accuracy: ±2.5 % of full scale  
 Repeatability: ±1 % of full scale  
 Inlet runs: 10 x DN / 2 x DN  
 Media temperature: 0...80 °C  
 Ambient temperature: -10...+60 °C  
 Max. media viscosity: see table

Measur. range	Measuring range start point [l/min]					Max. viscosity
	1 cSt	1.5 cSt	2 cSt	4 cSt	7 cSt	
04	0.5	1.5	3.0	-	-	2 cSt
07	0.8	1.5	3.0	-	-	2 cSt
10	1.3	1.3	3.5	-	-	2 cSt
16	2.0	2.0	3.5	-	-	4 cSt
22	3.2	3.2	3.2	6.0	-	4 cSt
32	4.0	4.0	4.0	3.2	12.5	7 cSt
40	4.0	4.0	4.0	8.0	15.0	7 cSt
50	5.0	5.0	5.0	9.0	16.5	7 cSt
63	6.3	6.3	6.3	10.0	18.5	7 cSt
80	8.0	8.0	8.0	11.0	20.5	7 cSt
99	10.0	10.0	10.0	11.5	23.0	7 cSt

When using viscous media the decreased Reynolds number causes a displacement of the measuring range start point to higher values. The measuring range end points values however stays unchanged.

**Max. pressure**

Connection	fixed	rotatable
standard version	10 bar	20 bar
reinforced version	20 bar	-

**Wetted parts**

Sensor housing: PPS, fibreglass-reinforced  
 Sensor: PVDF  
 Connections: brass, up to 32 l/min nickel plated, from 40 l/min blank or stainless steel 1.4404  
 Bluff body: PPS, fibreglass-reinforced or oxide ceramic (non-wear version)  
 Seal: NBR, EPDM or FPM  
 Response time: 1 s (at flow changes >10% FS)  
 Protection: IP 65  
 Weight: depending on version (see table)

**Technical Details** (continuation)

**DVZ-...S300, DVZ-...S30D**

Display: DUO-LED for switching condition and when range limit is exceeded

Switching output: relay change over, max. 1 A/30 V<sub>DC</sub> or active 24 V<sub>DC</sub>, N/C/N/O

Switch point: 10...90 % of full scale in 10 %-steps that can be configured by the customer using a rotary switch

Power supply: 24 V<sub>DC</sub> ±20 %

Power consumption: 25 mA

Electrical connection: plug M12x 1.5 pole

Measuring range overflow: flash of the DUO-LED (green/red) from 105 % of full scale

**DVZ-...F300, DVZ-...F390**

Pulse output: PNP, Open Collector, max. 200 mA

Frequency at ME: 500 Hz (...F300)  
50 ... 1000 Hz (...F390)

Power supply: 24 V<sub>DC</sub> ±20 %

Power consumption: 5 mA

Electrical connection: plug M12x1

Measuring range overflow: F<sub>out</sub> approx. 2 kHz from 105 % of f. s.

**DVZ-...L303; DVZ-...L343**

Output: 0(4)...20 mA, 3-wire

Max. load: 500 Ω

Power supply: 24 V<sub>DC</sub> ±20 %

Electrical connection: plug M12x1

Measuring range overflow: I<sub>out</sub> approx. 20.5 mA from approx. 103 % of full scale

**DVZ-...L443 (usage with AUF-3000)**

Output: 4...20 mA, 3-wire

Max. load: 500 Ω (250 Ω with AUF-3000)

Power supply: 24 V<sub>DC</sub> ±20 %

Electrical connection: plug DIN 43650

Measuring range overflow: I<sub>out</sub> approx. 20.5 mA from approx. 103 % of full scale

**DVZ-...C3xx (Compact electronics)**

Display: 3-digit LED

Analogue output: 0(4)...20 mA adjustable, max. 500 Ω (only for DVZ-...C34)

Switching output: 1 or 2 Open Collector PNP or NPN factory set, max. 300 mA

Contact function: N/C, N/O, frequency, programmable (frequency output not calibrated at f.s. approx. 500 - 600 Hz)

Programming: via 2 buttons

Power supply: 24 V<sub>DC</sub> ±20 %, 3-wire technology

Power consumption: approx. 100 mA

Electrical connection: plug M12, 5 pole

Measuring range overflow: display "OF" from 105 % of full scale

**Electrical Connections**

**DVZ-...S300**

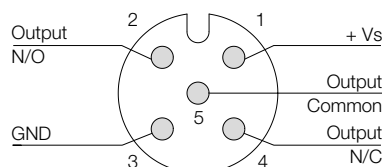

**DVZ-...S30D**

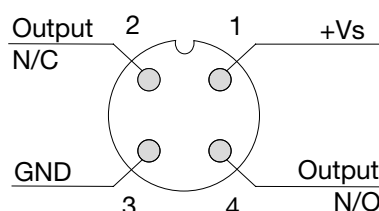

**DVZ-...F300; DVZ-...L3x3**

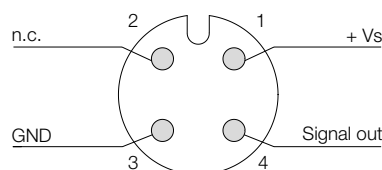

**DVZ-...L443**

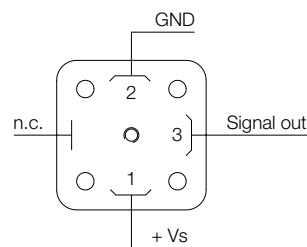

**DVZ-...C30x**

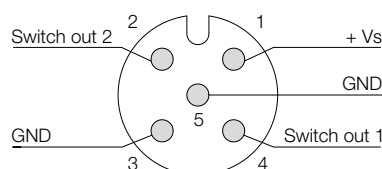

**DVZ-...C34**

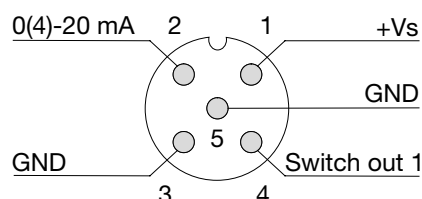

**Technical Details** (continuation)

**DVZ-...Exxx (Counter electronics)**

Display: LCD, 2 x 8 digit, illuminated total, part and flow quantities, units selectable

Quantity meter: 8-digit

Analogue output: 0(4)...20 mA adjustable

Load: max. 500 Ω

Switching output: 2 relays, max. 30 V<sub>AC/DC</sub>/2 A/60 VA

Settings: via 4 buttons

Functions: reset, MIN /MAX memory, flow monitor, monitoring for part and total quantity, language

Power supply: 24 V<sub>DC</sub> ±20 %, 3-wire technology

Power consumption: approx. 150 mA

Electrical connection: cable connection or M 12-plug

More technical details see data sheet ZED.

**DVZ-...Gxxx (Dosing electronics)**

Display: LCD, 2 x 8 digit, illuminated, dosing-, total-, and flow quantity, units selectable

Quantity meter: 8-digit

Dosage: 5-digit

Analogue output: 0(4)...20 mA adjustable

Load: max. 500 Ω

Switching output: 2 relays, max. 30 V<sub>AC/DC</sub>/2 A/60 VA

Settings: via 4 buttons

Functions: dosing (relais S2), start, stop, reset, fine dosing, correction amount, flow switch, total quantity, language

Power supply: 24 V<sub>DC</sub> ±20 %, 3-wire technology

Power consumption: approx. 150 mA

Electrical connection: cable connection or M 12-plug

More technical details see data sheet ZED.

**DVZ-...E14R, DVZ-...G14R Cable connection**

Wire number	DVZ-...E14R Counter electronics	DVZ-...G14R Dosing electronics
1	+24 V <sub>DC</sub>	+24 V <sub>DC</sub>
2	GND	GND
3	4-20 mA	4-20 mA
4	GND	GND
5	n.c.	Control 1*
6	reset part quantity	Control 2*
7	relay S1 open without current	relay S1 open without current
8		
9	relay S2 open without current	relay S2 open without current
10		

Control 1 <-> GND: Start-dosing  
 Control 2 <-> GND: Stop-dosing  
 Control 1 <-> Control 2 <-> GND: Reset-dosing

**Plug connection**

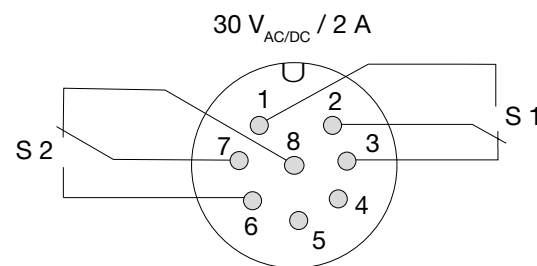
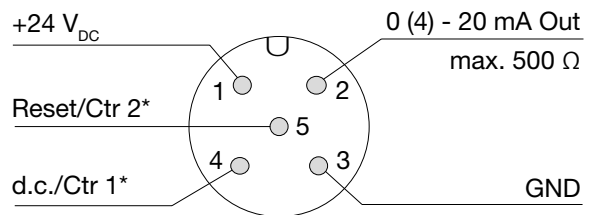

**Weight sensor**

Measuring range	Size	Connection fixed	Connection reinforced	Connection turnable
up to 32 l/min	¼", ⅜", ½"	approx. 450 g	approx. 600 g	approx. 800 g
up to 32 l/min	¾"	approx. 600 g	approx. 600 g	approx. 900 g
up to 32 l/min	1"	approx. 1050 g	approx. 950 g	approx. 950 g
40...100 l/min	¾"	approx. 1050 g	approx. 1300 g	approx. 1350 g
40...100 l/min	1"	approx. 900 g	approx. 1150 g	approx. 1400 g

**Weight electronic**

Model	Weight
DVZ-...F3x0 DVZ-...S30x DVZ-...Lxx3	approx. 80 g
DVZ-...C3xx	approx. 300 g
DVZ-...Exxx DVZ-...Gxxx	approx. 250 g

Total weight = weight sensor + weight electronic



**Order Details** (Example: DVZ-1 1 04 G2 S300)

Storage body	Connection/ seal	Measuring range	Connections		Electronics
			fixed	rotatable	
<b>DVZ-1..</b> = PPS <b>DVZ-2..</b> = ceramic <b>DVZ-3..*</b> = PPS/ reinforced version <b>DVZ-4..*</b> = ceramic/ reinforced version	..1..= brass/ NBR ..2..= st. steel/ NBR ..4..= brass/ EPDM ..5..= st. steel/ EPDM ..7..= brass/ FPM ..8..= st. steel/ FPM	..04.. = 0.5-4.5 l/min ..07.. = 0.8-6.5 l/min ..10.. = 1.3-10.0 l/min	..G2.. = G ¼ ..G3.. = G ⅜ ..G4.. = G ½ ..N2.. = ¼" NPT ..N3.. = ⅜" NPT ..N4.. = ½" NPT	..B2.. = G ¼ ..B3.. = G ⅜ ..B4.. = G ½ ..P2.. = ¼" NPT ..P3.. = ⅜" NPT ..P4.. = ½" NPT	<b>Switching output</b> ..S300 = M12-plug, relay ..S30D = active 24 V <sub>DC</sub> , M12-plug <b>Frequency output</b> ..F300 = M12-plug, 500 Hz ..F390 = M12-plug, 50...1000 Hz <b>Analogue output</b> ..L303 = M12-plug, 0-20 mA ..L343 = M12-plug, 4-20 mA ..L443 = DIN-plug, 4-20 mA <b>Compact electronics**</b> ..C30R = 2xOpen Coll., PNP ..C30M = 2xOpen Coll., NPN ..C34P = 4-20 mA, 1 xOpen Coll., PNP ..C34N = 4-20 mA, 1 xOpen Coll., NPN <b>Counter electronics</b> ..E14R = LCD, 0(4)-20 mA, 2 x relays, 1 m cable ..E34R = LCD, 0(4)-20 mA, 2 x relays, M 12-plug <b>Dosing electronics</b> ..G14R = LCD, 0(4)-20 mA, 2 x relays, 1m cable ..G34R = LCD, 0(4)-20 mA, 2 x relays, M 12-plug
		..16.. = 2.0-16.0 l/min	..G3.. = G ⅜ ..G4.. = G ½ ..G5.. = G ¾ ..N3.. = ⅜" NPT ..N4.. = ½" NPT ..N5.. = ¾" NPT	..B3.. = G ⅜ ..B4.. = G ½ ..B5.. = G ¾ ..P3.. = ⅜" NPT ..P4.. = ½" NPT ..P5.. = ¾" NPT	
		..22.. = 3.2-22.0 l/min ..32.. = 4.0-32.0 l/min	..G4.. = G ½ ..G5.. = G ¾ ..G6.. = G 1 ..N4.. = ½" NPT ..N5.. = ¾" NPT ..N6.. = 1" NPT	..B4.. = G ½ ..B5.. = G ¾ ..B6.. = G 1 ..P4.. = ½" NPT ..P5.. = ¾" NPT ..P6.. = 1" NPT	
		..40.. = 4.0-40 l/min ..50.. = 5.0-50 l/min ..63.. = 6.5-63 l/min ..80.. = 8.0-80 l/min ..99.. = 10.0-100 l/min	..G5.. = G ¾ ..G6.. = G 1 ..N5.. = ¾" NPT ..N6.. = 1" NPT	..B5.. = G ¾ ..B6.. = G 1 ..P5.. = ¾" NPT ..P6.. = 1" NPT	

\* Reinforced version only in combination with fixed connection

\*\*Please specify flow direction in the order

**Pressure Loss at Range End Value**

Model	Measuring range end value [l/min]	Pressure loss [mbar]
DVZ-__04	4.5	420
DVZ-__07	6.5	650
DVZ-__10	10.0	780
DVZ-__16	16.0	600
DVZ-__22	22.0	450
DVZ-__32	32.0	370
DVZ-__40	40.0	450
DVZ-__50	50.0	400
DVZ-__63	63.0	380
DVZ-__80	80.0	400
DVZ-__99	100.0	350

**Dimensions [mm]**

**DVZ sensor with fixed connection**

Measuring range up to 32 l/min

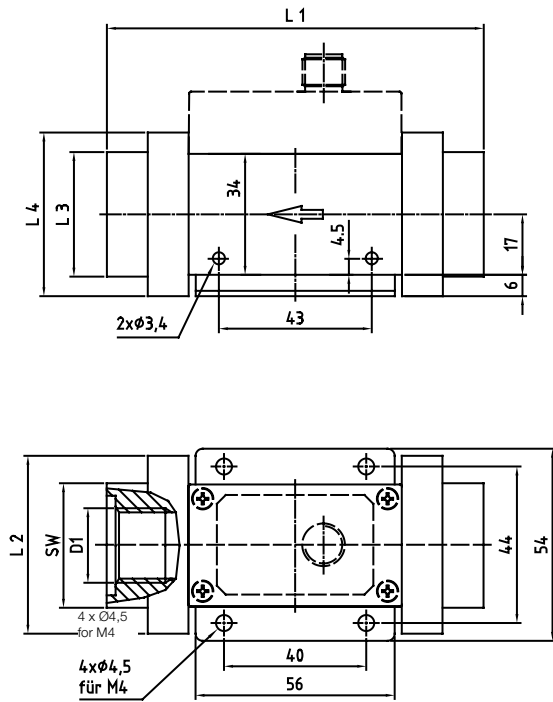

**DVZ sensor with fixed connection**

Measuring range from 40 l/min

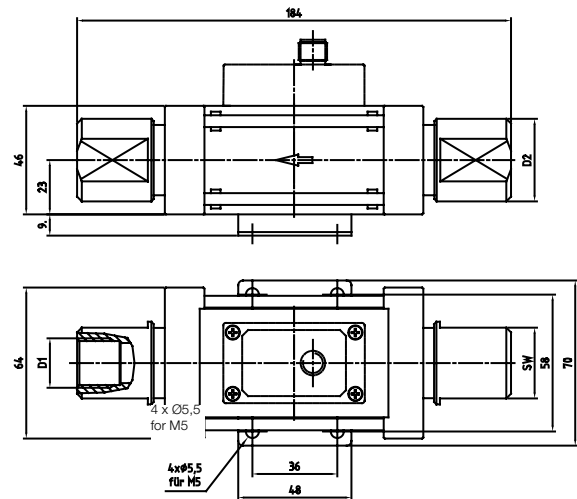

MB	..04 /..07 /..10	..04 /..07 /..10 /..16	..04 /..07 /..10 / ..16 /..22 /..32	..16 /..22 /..32	..22 /..32
D1	1/4"	3/8"	1/2"	3/4"	1"
SW	35	35	35	34	-
L1	100	100	106	120	128
L2	-	-	-	50	50
L3	35	35	35	34	-
L4	-	-	-	-	46

**DVZ sensor with reinforced connection**

Measuring range up to 32 l/min

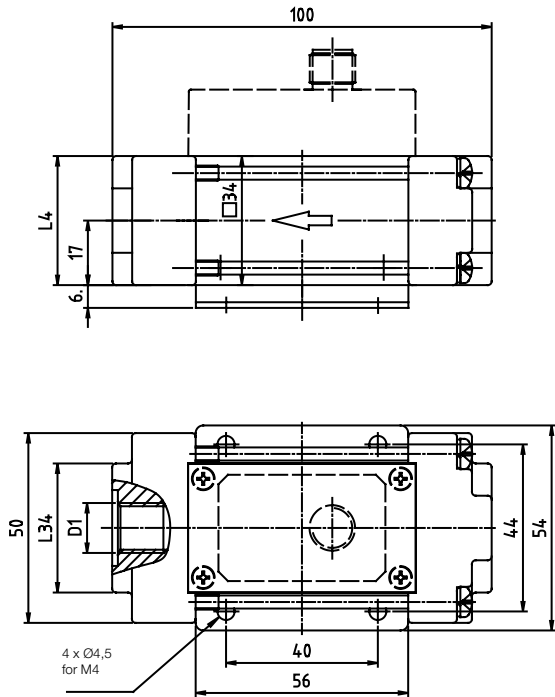

**DVZ sensor with reinforced connection**

Measuring range from 40 l/min

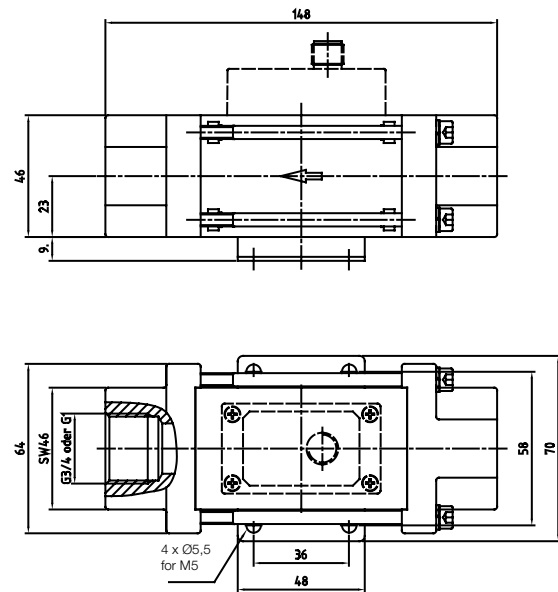

MB	..04 /..07 /..10	..04 /..07 /..10 /..16	..04 /..07 /..10 / ..16 /..22 /..32	..16 /..22 /..32	..22 /..32
D1	1/4"	3/8"	1/2"	3/4"	1"
SW	34	34	34	34	-
L1	100	100	106	120	128
L4	34	34	34	34	46

**DVZ sensor with turnable connection**

Measuring range up to 32 l/min

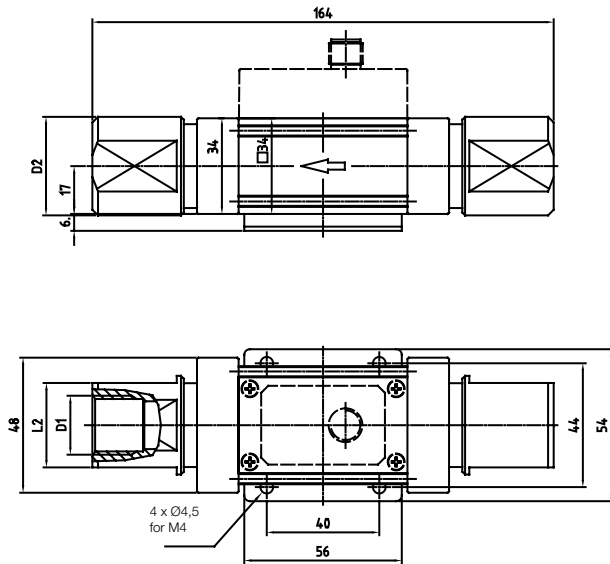

**DVZ sensor with turnable connection**

Measuring range from 40 l/min

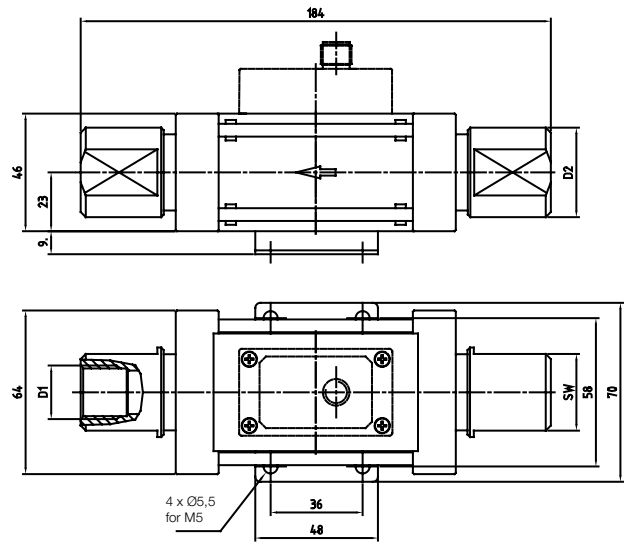

MB	..04 / ..07 / ..10	..04 / ..07 / ..10 / ..16	..04 / ..07 / ..10 / ..16 / ..22 / ..32	..16 / ..22 / ..32	..22 / ..32	..40 / ..50 / ..60 / ..80 / ..99	..40 / ..50 / ..60 / ..80 / ..99
D1	1/4"	3/8"	1/2"	3/4"	1"	3/4"	1"
D2	24	28	35	40	45	40	45
SW	19	24	30	36	41	36	41



DVZ-...S30x, DVZ-...F3x0, DVZ-...L3x3

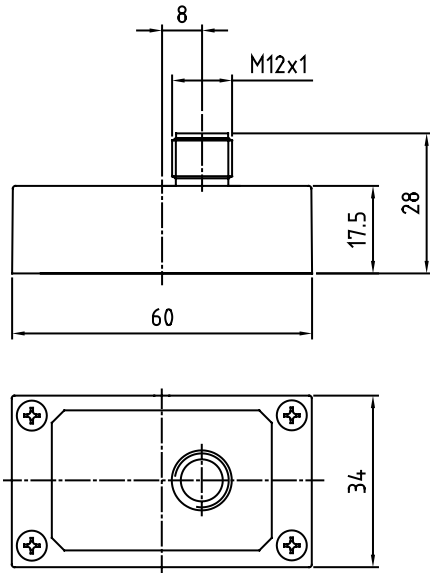

DVZ-...L443

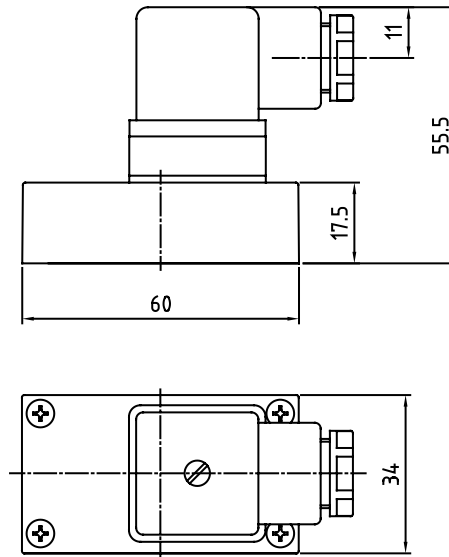

DVZ-...C3xx

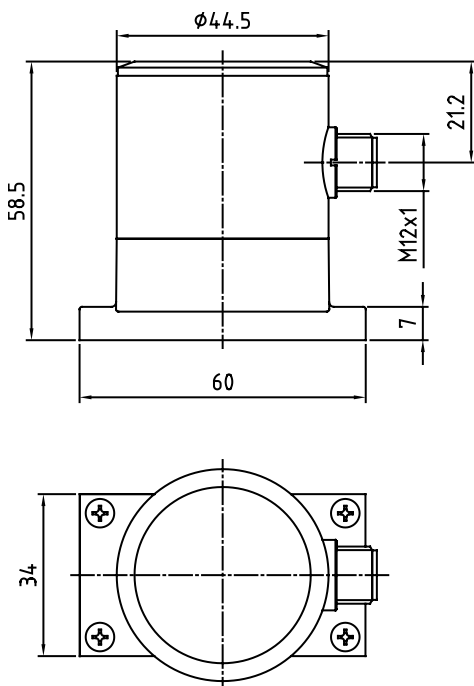

DVZ-...Exxx, DVZ-...Gxxx

