



## Flow Restrictors

for flow rates  
0.5 l/min ... 560 l/min



measuring  
•  
monitoring  
•  
analysing

REG



- $p_{max}$ : 200 bar;  $t_{max}$ : +300 °C
- Connections:  
screw thread G 1/2, G 3/4,  
G 1 1/2, G 2, G 2 1/4,  
G 2 1/2 and 3/4" NPT
- No auxiliary power required
- Easy to assemble
- Compact design
- Reliable — no wearing parts
- Energy-saving
- Easy to fit



12

**Design**

KOBOLD model REG flow restrictors serve to keep constant quantities of liquids in pipework systems. The REG rate regulators are ideally suited for the simple restriction to a preset value of throughputs of water, or of liquids similar to water. The flow restrictors ensure equilibrium, particularly in systems with many users and resulting pressure fluctuations caused by random flow conditions. In other words, the desired throughput is not exceeded.

Constant flow is achieved by two stainless steel diaphragms that are crosswise mounted and riveted together. The gap between the spring-loaded stainless steel plate and seal face is continuously varied as the differential pressure changes. As the differential pressure decreases the gap widens, and it closes as the pressure increases, thus maintaining a constant flow volume through the device.

**Notable Benefits**

- No auxiliary power required
- Easy to assemble
- Compact design
- Reliable - no wearing parts
- Energy-saving
- Easy to fit

**Technical Details**

Connections: female thread G 1/2, G 3/4  
 female/male thread G 1/2 ... G 3/4  
 male thread G 3/4  
 female thread 3/4" NPT  
 female/male thread 3/4" NPT  
 multiple element  
 G 1 1/2, G 2, G 2 1/4, G 2 1/2  
 male thread  
 flange versions  
 DN 20/25/32/40/50/65/80/100  
 ASME 3/4"/1"/1 1/4"/1 1/2"/2"/2 1/2"/3"/4"  
 Service temperature: -10 ... 300 °C  
 Operating pressure: max. 200 bar  
 Allowable operating pressure REG-82x...: see order details page 6 and 7  
 Differential pressure: min. 2.0 bar  
 max. 10 bar

**Materials** (see drawing for details)

Brass-version: brass and stainless steel  
 Stainless steel-version: all stainless steel

**Differential Pressure Curve**

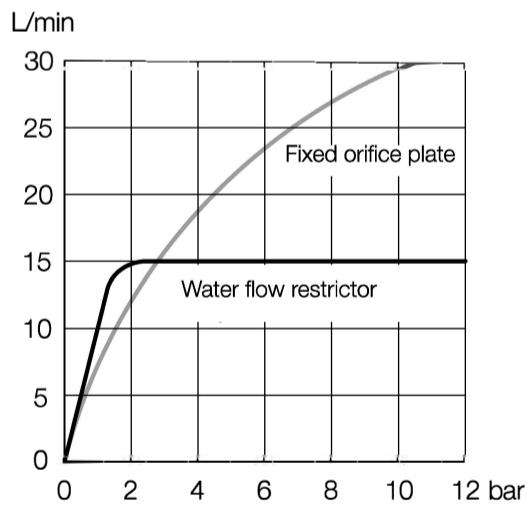

**REG-1x/REG-2x/REG-5x**

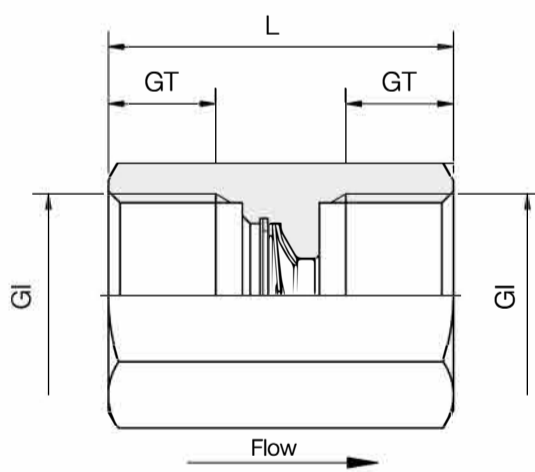

**REG-3x/REG-4x/REG-6x**

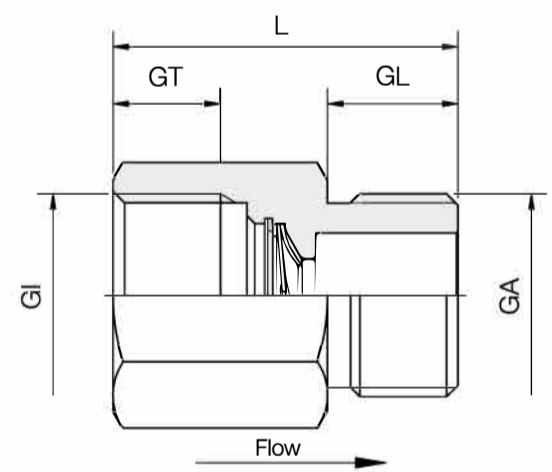

**REG-0x... 6x with Design and Materials**

1 Valve body	Brass Ms 58 or st. steel 1.4301
2 Pan	St. steel 1.4301
3 Spring star	St. steel 1.4310
4 Ring	St. steel 1.4301
5 Circlip	St. steel 1.4122

**REG-0x**

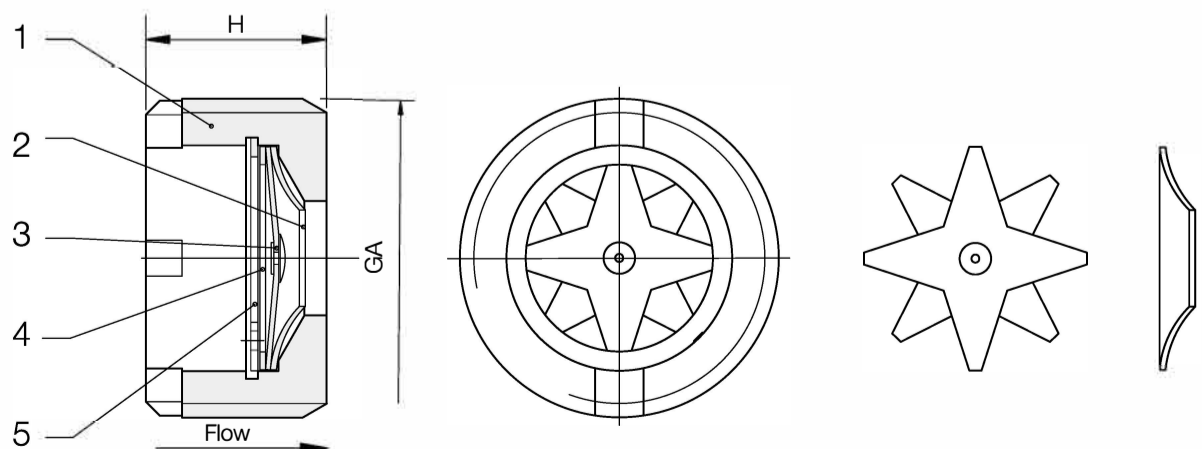



**Dimensions and Order Details single Elements G Screw Thread (Example: REG-0101)**

Dimensions		Male thread G 3/4		Female/female thread G 1/2		Female/female thread G 3/4		Female/male thread G 1/2		Female/male thread G 3/4	
L [mm]		-		42		50		42		50	
GT [mm]		-		14		16		14		16	
GL [mm]		-		-		-		14		16	
GI		-		G 1/2		G 3/4		G 1/2		G 3/4	
GA		G 3/4		-		-		G 1/2		G 3/4	
AF [mm]		-		27		36		27		36	
H [mm]		15		-		-		-		-	
Flow rate [l/min]	Tolerance [l/min]	Material		Material		Material		Material		Material	
		Brass	Stainless steel	Brass	Stainless steel	Brass	Stainless steel	Brass	Stainless steel	Brass	Stainless steel
0.5	±0.2	REG-0100	REG-0200	REG-1100D	REG-1200D	REG-2100D	REG-2200D	REG-3100D	REG-3200D	REG-4100D	REG-4200D
1	±0.2	REG-0101	REG-0201	REG-1101D	REG-1201D	REG-2101D	REG-2201D	REG-3101D	REG-3201D	REG-4101D	REG-4201D
2	±0.2	REG-0102	REG-0202	REG-1102D	REG-1202D	REG-2102D	REG-2202D	REG-3102D	REG-3202D	REG-4102D	REG-4202D
3	±0.4	REG-0103	REG-0203	REG-1103D	REG-1203D	REG-2103D	REG-2203D	REG-3103D	REG-3203D	REG-4103D	REG-4203D
4	±0.4	REG-0104	REG-0204	REG-1104D	REG-1204D	REG-2104D	REG-2204D	REG-3104D	REG-3204D	REG-4104D	REG-4204D
5	±0.5	REG-0105	REG-0205	REG-1105D	REG-1205D	REG-2105D	REG-2205D	REG-3105D	REG-3205D	REG-4105D	REG-4205D
6	±0.5	REG-0106	REG-0206	REG-1106D	REG-1206D	REG-2106D	REG-2206D	REG-3106D	REG-3206D	REG-4106D	REG-4206D
8	±0.5	REG-0108	REG-0208	REG-1108D	REG-1208D	REG-2108D	REG-2208D	REG-3108D	REG-3208D	REG-4108D	REG-4208D
9	±0.7	REG-0109	REG-0209	REG-1109D	REG-1209D	REG-2109D	REG-2209D	REG-3109D	REG-3209D	REG-4109D	REG-4209D
10	±0.7	REG-0110	REG-0210	REG-1110D	REG-1210D	REG-2110D	REG-2210D	REG-3110D	REG-3210D	REG-4110D	REG-4210D
11	±0.7	REG-0111	REG-0211	REG-1111D	REG-1211D	REG-2111D	REG-2211D	REG-3111D	REG-3211D	REG-4111D	REG-4211D
12	±0.7	REG-0112	REG-0212	REG-1112D	REG-1212D	REG-2112D	REG-2212D	REG-3112D	REG-3212D	REG-4112D	REG-4212D
16	±1.2	REG-0116	REG-0216	REG-1116D	REG-1216D	REG-2116D	REG-2216D	REG-3116D	REG-3216D	REG-4116D	REG-4216D
20	±1.2	REG-0120	REG-0220	REG-1120D	REG-1220D	REG-2120D	REG-2220D	REG-3120D	REG-3220D	REG-4120D	REG-4220D
25	±1.5	REG-0125	REG-0225	REG-1125D	REG-1225D	REG-2125D	REG-2225D	REG-3125D	REG-3225D	REG-4125D	REG-4225D
30	±1.5	REG-0130	REG-0230	REG-1130D	REG-1230D	REG-2130D	REG-2230D	REG-3130D	REG-3230D	REG-4130D	REG-4230D
40	±2.0	REG-0140	REG-0240	REG-1140D	REG-1240D	REG-2140D	REG-2240D	REG-3140D	REG-3240D	REG-4140D	REG-4240D

**Single Element**



**Dimensions and Order Details Single Elements NPT Screw Thread (Example: REG-5101)**

Dimensions		Female/female thread ¾" NPT		Female/male thread ¾" NPT	
L [mm]		45		45	
GT [mm]		14		14	
GL [mm]		-		17	
GI		¾" NPT		¾" NPT	
GA		-		¾" NPT	
AF [mm]		30		30	
H [mm]		-		-	
Flow rate [l/min]	Tolerance [l/min]	Brass	Stainless steel	Brass	Stainless steel
0,5	±0.2	REG-5100	REG-5200	REG-6100	REG-6200
1	±0.2	REG-5101	REG-5201	REG-6101	REG-6201
2	±0.2	REG-5102	REG-5202	REG-6102	REG-6202
3	±0.4	REG-5103	REG-5203	REG-6103	REG-6203
4	±0.4	REG-5104	REG-5204	REG-6104	REG-6204
5	±0.5	REG-5105	REG-5205	REG-6105	REG-6205
6	±0.5	REG-5106	REG-5206	REG-6106	REG-6206
8	±0.5	REG-5108	REG-5208	REG-6108	REG-6208
9	±0.7	REG-5109	REG-5209	REG-6109	REG-6209
10	±0.7	REG-5110	REG-5210	REG-6110	REG-6210
11	±0.7	REG-5111	REG-5211	REG-6111	REG-6211
12	±0.7	REG-5112	REG-5212	REG-6112	REG-6212
16	±1.2	REG-5116	REG-5216	REG-6116	REG-6216
20	±1.2	REG-5120	REG-5220	REG-6120	REG-6220
25	±1.5	REG-5125	REG-5225	REG-6125	REG-6225
30	±1.5	REG-5130	REG-5230	REG-6130	REG-6230
40	±2.0	REG-5140	REG-5240	REG-6140	REG-6240

Model	Weight
REG-0xxx	approx. 35 g
REG-1xxxD	approx. 130 g
REG-2xxxD	approx. 300 g
REG-3xxxD	approx. 110 g
REG-4xxxD	approx. 250 g

**Controller insert, Design and Materials for REG-92 and REG-82**

- 2 Pan St. steel 1.4301
- 3 Spring star St. steel 1.4310
- 4 Ring St. steel 1.4301
- 5 Circlip St. steel 1.4122

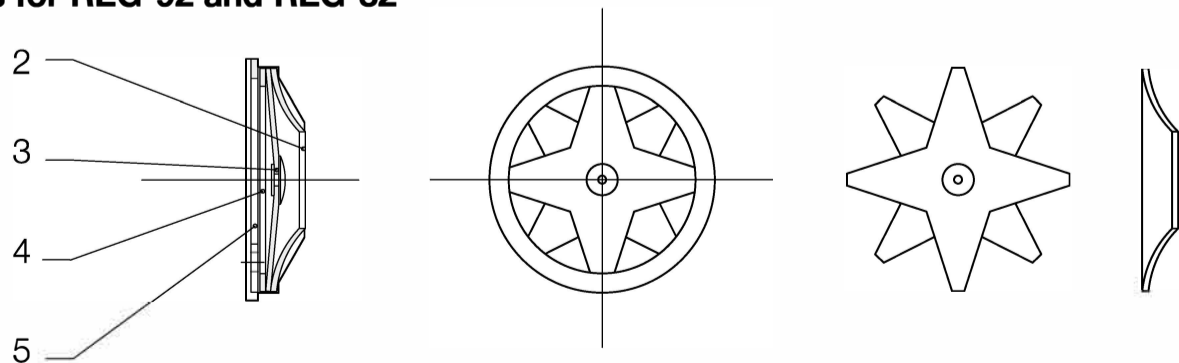

**Order Details Multiple Element** (Example: REG-92 R402 080)

Design	Size	Flow rate* in l/min
<b>REG-92...</b> Multiple element made of stainless steel 1.4301	..R402..= G 1 ½; 2-fold	1.0 ... 080
	..R403..= G 1 ½; 3-fold	1.5 ... 120
	..R503..= G 2; 3-fold	1.5 ... 120
	..R504..= G 2; 4-fold	2.0 ... 160
	..R585..= G 2 ¼; 5-fold	2.5 ... 200
	..R656..= G 2 ½; 6-fold	3.0 ... 240
	..R657..= G 2 ½; 7-fold	3.5 ... 280

\*The flow rate is calculated by adding the regulating inserts (see also single elements).

Example: The flow rate 55 l/min is obtained with one restrictor with two regulating inserts (30 plus 25 l/min).

**Multiple Element**



**Dimensions**

**REG-92R402**

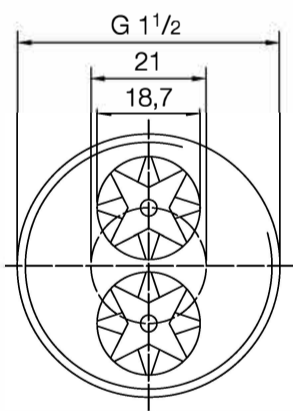

**REG-92R403**

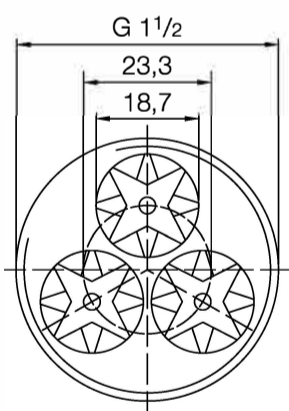

**REG-92R503**

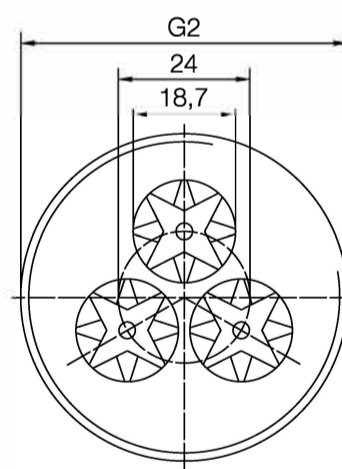

**REG-92R504**

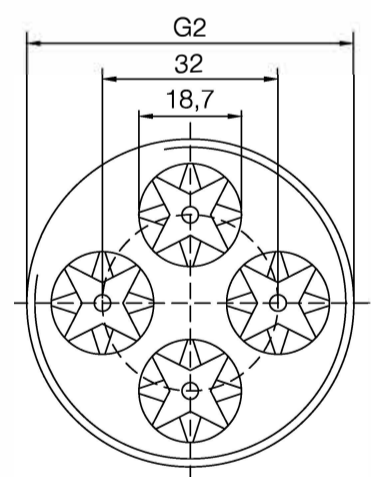

**REG-92R585**

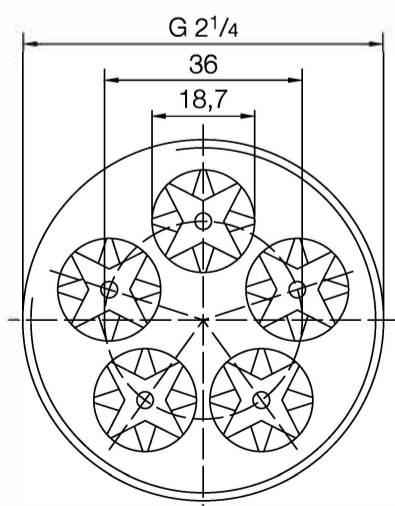

**REG-92R656**

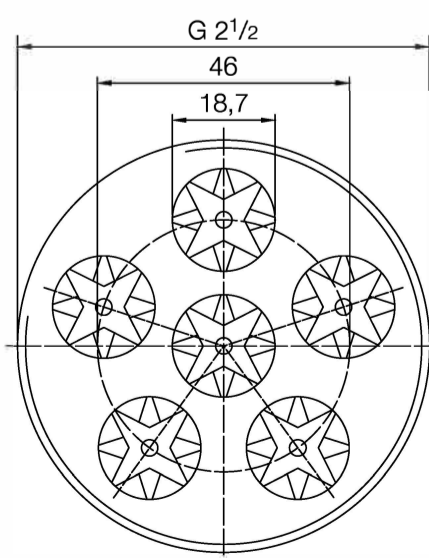

**REG-92R657**

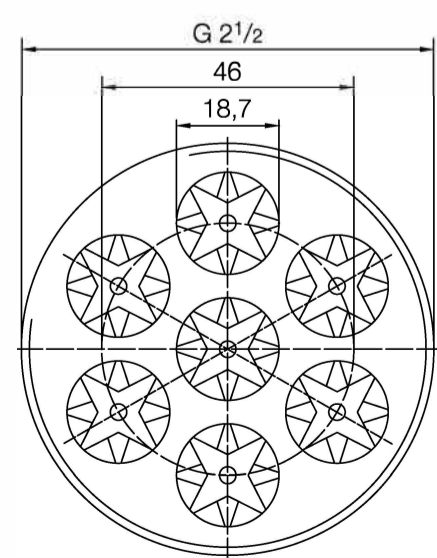

**Thickness: 15 mm**

**Order Details Multiple Element** (Example: REG-82 F65 7 280)

Design	Flange	Number of elements	Flow rate* in l/min
REG-82... Multiple element with flange EN 1092-1, PN 16/40 made of stainless steel 1.4404/1.4571	..F20.. = DN 20	..1.. = 1-fold	0.5 ... 040
	..F25.. = DN 25		
	..F32.. = DN 32	..2.. = 2-fold	1.0 ... 080
	..F40.. = DN 40	..2.. = 2-fold ..3.. = 3-fold	1.0 ... 080 1.5 ... 120
REG-82... Multiple element with flange EN 1092-1, PN 16 made of stainless steel 1.4404/1.4571	..F50.. = DN 50	..2.. = 2-fold	1.0 ... 080
		..3.. = 3-fold	1.5 ... 120
		..4.. = 4-fold	2.0 ... 160
	..F65.. = DN 65	..5.. = 5-fold	2.5 ... 200
		..4.. = 4-fold	2.0 ... 160
		..5.. = 5-fold	2.5 ... 200
		..6.. = 6-fold	3.0 ... 240
	..F80.. = DN 80	..7.. = 7-fold	3.5 ... 280
		..5.. = 5-fold	2.5 ... 200
		..6.. = 6-fold	3.0 ... 240
		..7.. = 7-fold	3.5 ... 280
		..8.. = 8-fold	4.0 ... 320
	..F1H.. = DN 100	..9.. = 9-fold	4.5 ... 360
		..6.. = 6-fold	3.0 ... 240
..7.. = 7-fold		3.5 ... 280	
..8.. = 8-fold		4.0 ... 320	
..Z.. = 10-fold		5.0 ... 400	
..B.. = 12-fold		6.0 ... 480	
	..D.. = 14-fold	7.0 ... 560	

\*The flow rate is calculated by adding the regulating inserts (see also single elements).

Example: The flow rate 55 l/min is obtained with one restrictor with two regulating inserts (30 plus 25 l/min).

**Dimensions [mm]**

Example: REG-82F657...

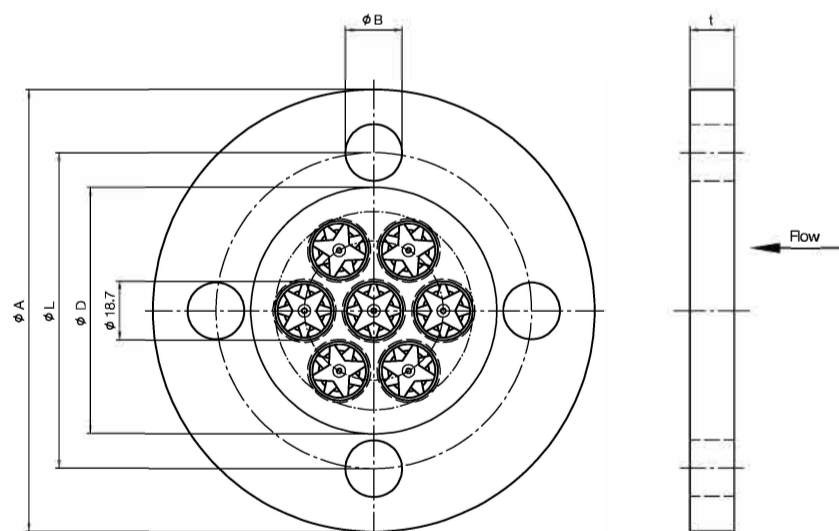

**REG-82 Fxx flange dimensions for PN 16-40**

DN	PN	Outer-Ø [A]	Bolt circle-Ø [L]	Hole-Ø [B]	Sealing surface-Ø [D]	Flange thickness [t]*
20	16-40	105	75	14	58	18
25		115	85		68	
32		140	100		78	
40		150	110		88	
50	16	165	125	18	102	20
65		185	145		122	
80		200	160		138	
100		220	180		158	

\* Sealing surfaces on both sides



**Order Details Multiple Element** (Example: REG-82 A65 7 280)

Design	Flange	Number of elements	Flow rate* in l/min
<b>REG-82...</b> Multiple element with flange ASME class 150 B16.5 made of stainless steel 1.4404/1.4571	..A20.. = ¾"	..1.. = 1-fold	0.5 ... <b>040</b>
	..A25.. = 1"		
	..A32.. = 1¼"		
	..A40.. = 1½"		
	..A50.. = 2"	..2.. = 2-fold	1.0 ... <b>080</b>
	..A65.. = 2½"	..3.. = 3-fold	1.5 ... <b>120</b>
		..4.. = 4-fold	2.0 ... <b>160</b>
		..5.. = 5-fold	2.5 ... <b>200</b>
		..6.. = 6-fold	3.0 ... <b>240</b>
		..7.. = 7-fold	3.5 ... <b>280</b>
		..A80.. = 3"	..5.. = 5-fold
	..6.. = 6-fold		3.0 ... <b>240</b>
	..7.. = 7-fold		3.5 ... <b>280</b>
	..8.. = 8-fold		4.0 ... <b>320</b>
	..9.. = 9-fold		4.5 ... <b>360</b>
	..A1H.. = 4"	..6.. = 6-fold	3.0 ... <b>240</b>
		..7.. = 7-fold	3.5 ... <b>280</b>
		..8.. = 8-fold	4.0 ... <b>320</b>
..Z.. = 10-fold		5.0 ... <b>400</b>	
..B.. = 12-fold		6.0 ... <b>480</b>	
..D.. = 14-fold		7.0 ... <b>560</b>	

\*The flow rate is calculated by adding the regulating inserts (see also single elements).

Example: The flow rate 55 l/min is obtained with one restrictor with two regulating inserts (30 plus 25 l/min).

**Dimensions [mm]**

Example: REG-82A657

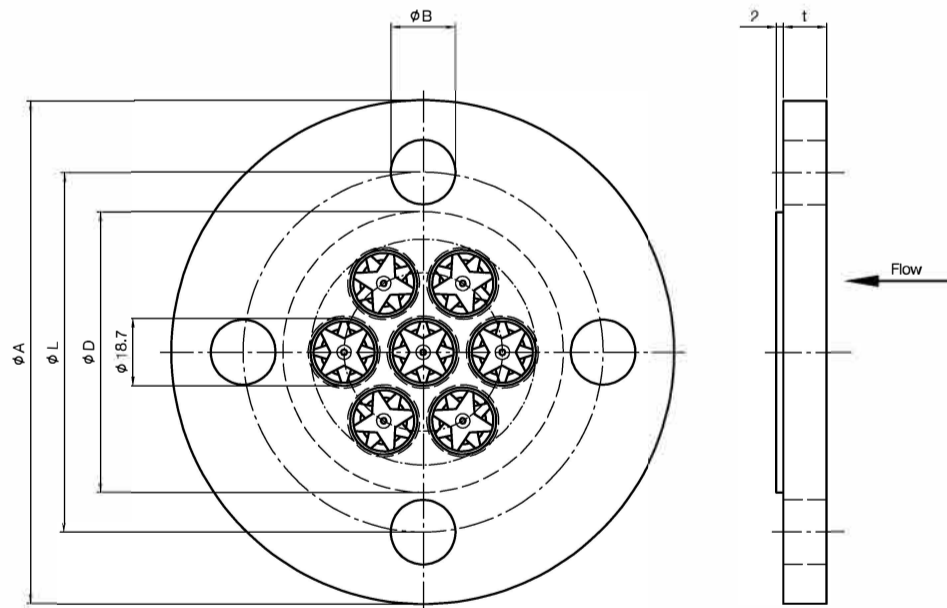

**REG-82 Axx flange dimensions ASME B16.5**

NPS	Class	Outer-Ø [A]	Bolt circle-Ø [L]	Hole-Ø [B]	Sealing surface-Ø [D]	Flange thickness [t]*
¾"	150	100	69.9	15.9	42.9	11.2
1"		110	79.4		50.8	12.7
1¼"		115	88.9		63.5	14.3
1½"		125	98.4		73.0	15.9
2"		150	120.7	19.1	92.1	17.5
2½"		180	139.7		104.8	20.7
3"		190	152.4		127.0	22.3
4"		230	190.5		157.2	22.3

\* Sealing surfaces on both sides