



Pressure Sensor with Ceramic Sensor Element



measuring
•
monitoring
•
analysing

SEN-86

Option:
Pluggable Sandwich
Display Model AUF



- Gauge pressure
- Internal diaphragm
- Measuring range:
-1...0 to 0...600 bar
- Temperature (medium):
max. 85 °C
- Accuracy class: 0.5
- Material:
Stainless steel and ceramic
- Connection: G ½



P2

KOBOLD companies worldwide:

ARGENTINA, AUSTRALIA, AUSTRIA, BELGIUM, BULGARIA, CANADA, CHILE, CHINA, COLOMBIA, CZECHIA, EGYPT, FRANCE, GERMANY, GREAT BRITAIN, HUNGARY, INDIA, INDONESIA, ITALY, MALAYSIA, MEXICO, NETHERLANDS, PERU, POLAND, REPUBLIC OF KOREA, ROMANIA, SINGAPORE, SPAIN, SWITZERLAND, TAIWAN, THAILAND, TUNISIA, TURKEY, USA, VIETNAM

KOBOLD Messring GmbH
Nordring 22-24
D-65719 Hofheim/Ts.
Head Office:
+49(0)6192 299-0
+49(0)6192 23398
info.de@kobold.com
www.kobold.com

Description

KOBOLD Pressure sensors model SEN-86 are inexpensive pressure sensors with thick film ceramic pressure element. With their accuracy, reliability and compact design, they are perfectly suitable for OEM applications in medium to high quantities.

The materials and technology used make these pressure sensors insensitive to chemically aggressive media and mechanical load. Particularly hydraulics systems with their high and fast pressure peaks are thus preferred applications.

Dimensions [mm]

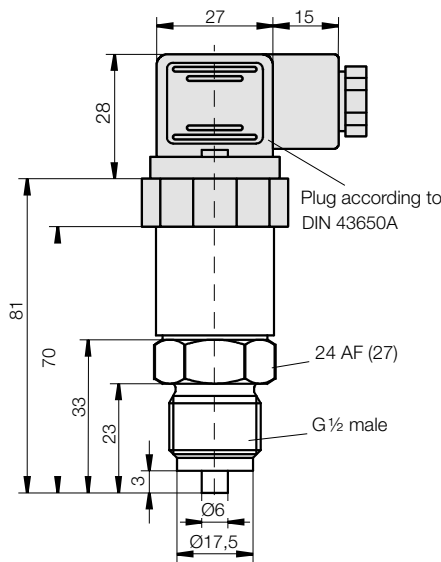

Technical Details

Technology:	Internal diaphragm
Pressure type:	Gauge pressure
Housing:	Stainless steel 1.4305
Connection:	G 1/2 male, stainless steel 1.4301 (NPT, UNF on request)
Sensor element:	Ceramic (Al ₂ O ₃)
Measuring principle:	Thick film technology (DMS)
O-Ring:	NBR
Max. Temperature:	Storage: -30...+100°C medium: -20...+85°C ambient: -30...+100°C
Pressure limitation:	< 60 bar: 2 x range ≥ 60 bar: 1.5 x range
Accuracy class:	SEN-86*0: 0.5
Repeatability:	SEN-86*0: ≤ ± 0.15 % of full scale
Characteristic deviation:	SEN-86*0: ≤ ± 0.3 % of full scale
Stability per year:	≤ ± 0.2 % of full scale (under reference conditions)
Electrical connection:	Plug according to DIN 43 650 A, plug M12x1, cable connection
Auxiliary power:	15...32 V _{DC}
Output:	4 - 20 mA (2-wire), 0 - 10 V _{DC}
Load (Ω):	≤ (U _B -15V)/0,02 A (for 4 - 20 mA)
Response time:	≤ 1 ms (within 10 - 90 % of full scale)
Compensated range:	- 25...+85 °C
Temperature drift:	Zero point: SEN-86*0: ≤ ± 0.02 % full scale/K auf Messspanne: SEN-86*0: ≤ ± 0.01 % full scale/K
Protection:	IP 65 (SEN-860..; SEN-863..) IP 68 (SEN-865..)

Anwendungen

- Plant engineering
- Environmental engineering
- Machine Building
- Cooling circuit

Order Details Sensor (Example: SEN-8600 C315)

Electrical connection	Class	Model	Output	Measuring range	Connection	
DIN plug; IP 65	0.5	SEN-8600..		C 315 = -1 ... 0 bar C 505 = -1 ... 0.6 bar C 515 = -1 ... 1.5 bar C 525 = -1 ... 3 bar C 535 = -1 ... 5 bar C 545 = -1 ... 9 bar C 555 = -1 ... 15 bar B 025 = 0 ... 1 bar B 035 = 0 ... 1.6 bar B 045 = 0 ... 2.5 bar B 055 = 0 ... 4 bar B 065 = 0 ... 6 bar B 075 = 0 ... 10 bar B 085 = 0 ... 16 bar A 095 = 0 ... 25 bar A 105 = 0 ... 40 bar A 115 = 0 ... 60 bar A 125 = 0 ... 100 bar A 135 = 0 ... 160 bar A 140 = 0 ... 200 bar A 145 = 0 ... 250 bar A 155 = 0 ... 400 bar A 165 = 0 ... 600 bar	H 315 = -30 ... 0 in Hg P 025 = 0 ... 15 psi g P 045 = 0 ... 30 psi g P 055 = 0 ... 50 psi g P 060 = 0 ... 60 psi g P 065 = 0 ... 100 psi g P 075 = 0 ... 150 psi g P 085 = 0 ... 200 psi g P 090 = 0 ... 300 psi g P 095 = 0 ... 350 psi g P 100 = 0 ... 500 psi g P 105 = 0 ... 600 psi g P 115 = 0 ... 1000 psi g P 125 = 0 ... 1450 psi g P 130 = 0 ... 2000 psi g P 135 = 0 ... 2300 psi g P 140 = 0 ... 3000 psi g P 145 = 0 ... 3600 psi g P 150 = 0 ... 5000 psi g P 155 = 0 ... 5800 psi g P 160 = 0 ... 7500 psi g P 165 = 0 ... 10000 psi g	Thread without = G 1/2 male Y = silicone free Y = pressure connection 1.4539 instead of 1.4301 Y = FPM instead of NBR o-ring N = 1/2" NPT male
M12 plug; IP 65	0.5	SEN-8630..	without = 4 - 20 mA /2 = 0 - 10 V			
Cable connection; IP 68	0.5	SEN-8650..				



Pressure Sensor with Ceramic Sensor Element



measuring
•
monitoring
•
analysing

SEN-87



Option:
Pluggable Sandwich
Display Model AUF

- Gauge pressure
- Internal diaphragm
- Measuring range:
-1...0 to 0...600 bar
- Temperature (medium):
max. 85 °C
- Accuracy class: 0.5
- Material:
Stainless steel and ceramic
- Connection: G ¼



P2

KOBOLD companies worldwide:

ARGENTINA, AUSTRALIA, AUSTRIA, BELGIUM, BULGARIA, CANADA, CHILE, CHINA, COLOMBIA, CZECHIA, EGYPT, FRANCE, GERMANY, GREAT BRITAIN, HUNGARY, INDIA, INDONESIA, ITALY, MALAYSIA, MEXICO, NETHERLANDS, PERU, POLAND, REPUBLIC OF KOREA, ROMANIA, SINGAPORE, SPAIN, SWITZERLAND, TAIWAN, THAILAND, TUNISIA, TURKEY, USA, VIETNAM

KOBOLD Messring GmbH
Nordring 22-24
D-65719 Hofheim/Ts.
Head Office:
+49(0)6192 299-0
+49(0)6192 23398
info.de@kobold.com
www.kobold.com

Description

KOBOLD Pressure sensors model SEN-87 are inexpensive pressure sensors with thick film ceramic pressure element. With their accuracy, reliability and compact design, they are perfectly suitable for OEM applications in medium to high quantities. The materials and technology used make these pressure sensors insensitive to chemically aggressive media and mechanical load. Particularly hydraulics systems with their high and fast pressure peaks are thus preferred applications.

Dimensions [mm]

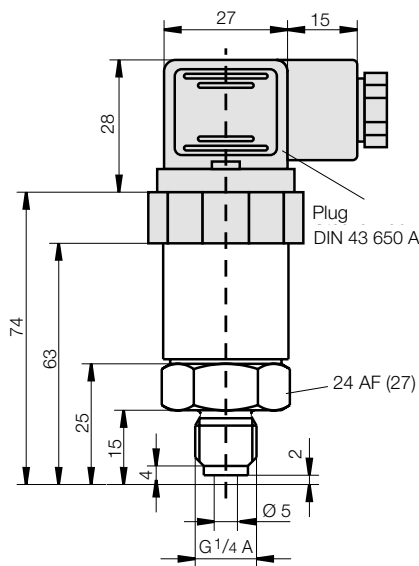

Applications

- Plant engineering
- Environmental engineering
- Machine Building
- Cooling circuit

Technical Details

Technology: Internal diaphragm
 Pressure type: Gauge pressure
 Housing: Stainless steel 1.4305
 Connection: G ¼ male, stainless steel 1.4301 (NPT, UNF on request)
 Sensor element: Ceramic (Al₂O₃)
 Measuring principle: Thick film technology (DMS)
 O-Ring: NBR
 Max. Temperature: Storage: -30...+100°C
 medium: -20...+85°C
 ambient: -30...+100°C
 Pressure limitation: < 60 bar: 2 x range
 ≥ 60 bar: 1.5 x range
 Accuracy class: SEN-87+0: 0.5
 Repeatability: SEN-87+0: ≤ ± 0.15 % of full scale
 Characteristic deviation: SEN-87+0: ≤ ± 0.3 % of full scale
 Stability per year: ≤ ± 0.2 % of full scale (under reference conditions)
 Electrical connection: Plug according to DIN 43 650 A, plug M12x1, cable connection
 Auxiliary power: 15...32 V_{DC}
 Output: 4 - 20 mA (2-wire), 0 - 10 V_{DC}
 Load (Ω): ≤ (U_B-15V)/0,02 A (für 4 - 20 mA)
 Response time: ≤ 1 ms (within 10 - 90 % of full scale)
 Temp. comp. range: -25...+85°C
 Temperature drift: Zero point: SEN-87+0: ≤ ± 0.02 % FS/K
 span: SEN-87+0: ≤ ± 0.01 % FS/K
 Protection: IP 65 (SEN-870..; SEN-873..) IP 68 (SEN-875..)

Order Details Sensor (Example: SEN-8700 C315)

Electrical connection	Class	Model	Output	Measuring range	Connection	
DIN plug; IP 65	0.5	SEN-8700..	without = 4 - 20 mA /2 = 0 - 10 V	C 315 = -1 ... 0 bar C 505 = -1 ... 0.6 bar C 515 = -1 ... 1.5 bar C 525 = -1 ... 3 bar C 535 = -1 ... 5 bar C 545 = -1 ... 9 bar C 555 = -1 ... 15 bar B 025 = 0 ... 1 bar B 035 = 0 ... 1.6 bar B 045 = 0 ... 2.5 bar B 055 = 0 ... 4 bar B 065 = 0 ... 6 bar B 075 = 0 ... 10 bar B 085 = 0 ... 16 bar A 095 = 0 ... 25 bar A 105 = 0 ... 40 bar A 115 = 0 ... 60 bar A 125 = 0 ... 100 bar A 135 = 0 ... 160 bar A 140 = 0 ... 200 bar A 145 = 0 ... 250 bar A 155 = 0 ... 400 bar A 165 = 0 ... 600 bar	H 315 = -30 ... 0 in Hg P 025 = 0 ... 15 psi g P 045 = 0 ... 30 psi g P 055 = 0 ... 50 psi g P 060 = 0 ... 60 psi g P 065 = 0 ... 100 psi g P 075 = 0 ... 150 psi g P 085 = 0 ... 200 psi g P 090 = 0 ... 300 psi g P 095 = 0 ... 350 psi g P 100 = 0 ... 500 psi g P 105 = 0 ... 600 psi g P 115 = 0 ... 1000 psi g P 125 = 0 ... 1450 psi g P 130 = 0 ... 2000 psi g P 135 = 0 ... 2300 psi g P 140 = 0 ... 3000 psi g P 145 = 0 ... 3600 psi g P 150 = 0 ... 5000 psi g P 155 = 0 ... 5800 psi g P 160 = 0 ... 7500 psi g P 165 = 0 ... 10000 psi g	Thread without = G ¼ male Y = silicone free Y = pressure connection 1.4539 instead of 1.4301 Y = FPM instead of NBR o-ring N = ¼" NPT male
M12 plug; IP 65	0.5	SEN-8730..				
Cable connection; IP 68	0.5	SEN-8750..				