

Flow Meters for very Low Flows

with and without Control Valve



- Flow rates:
Water 0.25–1.5 to 5–80 l/h
Air 20–80 l/h to 0.5–2.5 Nm³/h
- Accuracy: ±6% f.s.
- Pmax 6 bar, Tmax +120°C
- Connection: 1/8 NPT female
- Materials:
polycarbonate and brass
polysulfone and stainless steel



KOBOLD offices exist in the following countries:

**ARGENTINA, AUSTRIA, BELGIUM, CANADA, CHINA,
FRANCE, GERMANY, GREAT BRITAIN, NETHERLANDS,
POLAND, SINGAPORE, SWITZERLAND, USA, VENEZUELA**

KOBOLD Messring GmbH
Nordring 22-24
D-65719 Hofheim/Ts.
☎ (06192) 299-0
Fax (06192) 23398
E-mail: info.de@kobold.com
Internet: www.kobold.com

Model:
KSV



Description

The flow meter and switch for very low flows model KSV for liquids or air operates on the suspended float principle. The direction of flow is from bottom to top, and the installation position is vertical. The indication point is the upper edge of the ball.

The device has been designed as a simple and thus economical measuring system. The optional needle valve allows economical control. The device has been designed for panel mounting.

Advantages:

- Acid and caustic-proof
- Suitable for sterilization (120°C); only material combination III + IV
- Shock resistant
- Small size
- Light weight
- Easy to install

Dimensions

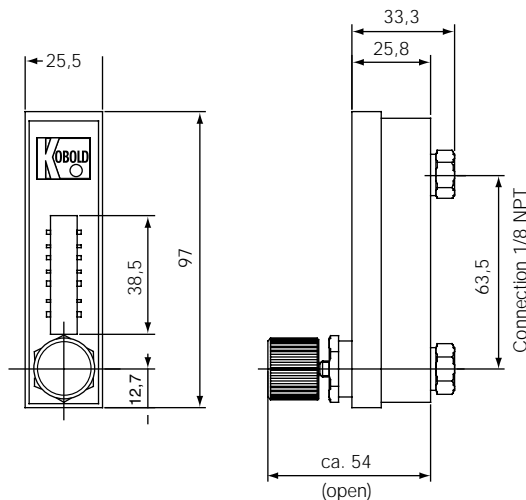

Panel cut-out: 93 + 0.5 mm x 23 + 0.5 mm

Technical Details

- Connection: 1/8 NPT female
option: hose connector, Ø 8 mm, polyamide straight version (order no. ...G) angle version (order no. ...W)
- Inlet & outlet: horizontal
- Measuring accuracy: ±6% of full scale value
- Repeatability: 1% of full scale value
- Operating pressure: max. 6.0 bar (device is not suitable for vacuum pressure)
- Operating temperature: polycarbonate: -20°C to +80°C
polysulfone: -20°C to +120°C

Contact (optional)

- Order no.: R
- Reed contact fixed in min. position.
- Function: NC contact with increasing flow rate.
- Maximum electrical values: 24 V / 0.1 A / 1 watt.
- (Please note when using the contact the measuring range do may change from that shown below)
- Float material: magnet SmCo.

Contact protection relay

- Type: MSR 10
- Allowed loading: 230 VAC / 1100 VA / 5A
- Technical Details: see brochure Z2

Material combinations

	Housing	Connection	O-rings
I	Polycarbonate	Brass, nickel-pl.	Buna N
II	Polycarbonate	St. steel, 1.4305	Viton
III	Polysulfone	Brass, nickel-pl.	Buna N
IV	Polysulfone	St. steel, 1.4305	Viton

Order Details (example: KSV 1204L, material combination II (PC, st. steel) with control valve. Meas. range 50–150 NI/h air.)

Water	Float	with control valve material combination				without control valve material combination				Air Add suffix “..L” to code
		I	II	III	IV	I	II	III	IV	
l/h										l _n /h
0.25-1.5	Glass	KSV 1101	KSV 1201	KSV 1301	KSV 1401	KSV 2101	KSV 2201	KSV 2301	KSV 2401	20-80
1-4	St. steel	KSV 1104	KSV 1204	KSV 1304	KSV 1404	KSV 2104	KSV 2204	KSV 2304	KSV 2404	50-150
0.5-6	Glass	KSV 1106	KSV 1206	KSV 1306	KSV 1406	KSV 2106	KSV 2206	KSV 2306	KSV 2406	50-300
2.5-15	St. steel	KSV 1116	KSV 1216	KSV 1316	KSV 1416	KSV 2116	KSV 2216	KSV 2316	KSV 2416	50-500
5-30	Titan	KSV 1135	KSV 1235	KSV 1335	KSV 1435	KSV 2135	KSV 2235	KSV 2335	KSV 2435	0.25-1.5 Nm ³ /h
10-80	Hard metal	KSV 1180	KSV 1280	KSV 1380	KSV 1480	KSV 2180	KSV 2280	KSV 2380	KSV 2480	0.5-2.5 Nm ³ /h

Option: hose connector, straight version item code. Suffix G / angle version item code. Suffix W plastic coupling for PE and PP (polypropylene) piping ND 6 mm with box nut Suffix K.