

tyco

Flow Control

SAPAG**A full range of API 526 flanged safety relief valves for process applications, gas, steam and liquid.****Features**

- Full compliance to API RP 520 and standards 526, 527.
- Certified ASME Section VIII on air, steam and water.
- TÜV approved (AD Merkblatt A2).
- Forged Integral inlet nozzle.
- High flow coefficient.
- Top guided nozzle.
- Easy blowdown adjustment.
- Swivel disc.
- Blow out proof body to bonnet gasket.
- Special "Hightemp" trim for steam applications.
- NACE Compliance.

8100: Gas and Steam service.**8200:** Liquid service.**Scope**

Size : 1" to 12" inlet

Orifice D (0.71cm²) to W (393 cm²)

Set pressure 0.5 bar to 414 bar

Conventional or balanced bellows

Metal to metal seat or soft seat

Carbon Steel, Stainless Steel, Duplex, Monel etc...

Connections

Safety relief valve connections are available in ASME-ANSI flange standards as well as DIN. Other standards may be manufactured on request.

**Series 8100/8200 High Performance Safety Relief Valves**

The type 8100 is a flanged, spring loaded, full lift, adjustable blowdown, integral nozzle safety relief valve designed according to API Std 526.

The type 8200 is the "liquid" version of the type 8100.

It is available in 14 orifice sizes, "D" through "T", plus two extra large orifices designated "V" and "W".

The pressure range is from less than one bar up to 414 bar, pressure rating from Cl.150 lbs to Cl.2500 lbs.

The performance of the types 8100/8200 is certified by independent bodies:

- "UV" stamp (National Board certification according to the rules of the ASME Code, section VIII), with capacities certified on air, steam and water
- TÜV approval
- Other approvals (ask the factory for details).

Conventional type 8100

Most of the applications on gas or vapours are covered by the conventional type 8100. It is available in many different materials for high or low service temperature, as well as stainless steel for corrosive service. Available part lists are published in pages 5 to 8, however special materials may be manufactured upon request. Contact the factory for assistance.

Steam service type 8100.V0/V1/V2/V3

The 8100.V's series have been developed from the 8100 series for steam applications. The Type 8100.V0 is an open bonnet, plain lifting lever, alloy steel spring design, suitable for steam applications not exceeding 300°C.

The Type 8100.V3 is also an open bonnet, plain lifting lever, alloy steel spring design, using a special high temperature trim : Flexible "HIGHTEMP" " disc made from a high strength martensitic stainless steel grade and a Nickel-Copper alloy guide. The Type 8100.V3 can be used up to 427°C.

When the valves are discharging into a closed system, closed bonnet designs 8100.V1 or .V2 must be used. Both valves feature the special high temperature trim and can be used with a balancing bellows when necessary.

Feature	8100.V0	8100.V3	8100.V1	8100.V2
Bonnet	open	open	closed	closed
Lift lever	plain	plain	packed	packed
Spring	alloy steel	alloy steel	alloy steel	tungsten alloy
Disc	standard	"hightemp"	"hightemp"	"hightemp"
Guide	stainless steel	nickel copper alloy	nickel copper alloy	nickel copper alloy
Bellows	not available	not available	8190.V1	8190.V2
Maxi t°	300°C	427°C	300°C	427°C

High temperature service type 8120

The type 8120.WC6 is to be used on high temperature service between 428 and 538°C. This design includes CrMo alloy body and bonnet and Tungsten alloy or Ni-Cr alloy spring. For extremely high temperature, up to 815°C, the type 8120.T2 with an open bonnet, Tungsten alloy or Ni-Cr alloy spring, austenitic CrNiMo stainless steel casing and 25%Cr-20%Ni alloy trim shall be used.

When modified with balancing bellows, 8120 series become 8150.

High temperature service

Service temperature	Open bonnet	Closed bonnet	Closed bonnet & bellows
< 300°C	8100.V0	8100.V1	8190.V1
< 427°C	8100.V3	8100.V2	8190.V2
< 538°C		8120.WC6	8150.WC6
< 815°C	8120.T2		

Conventional Type 8100

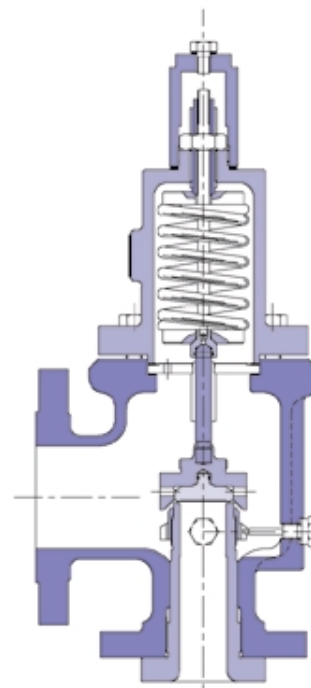

Flexible "High temp" Disc

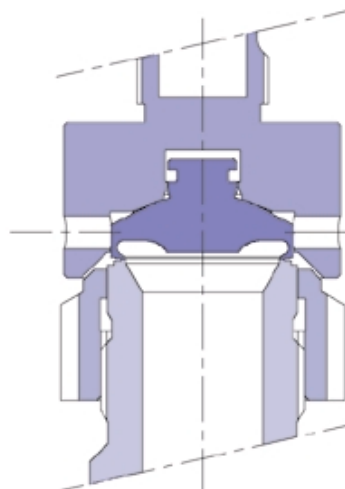

Liquid Trim Type 8200

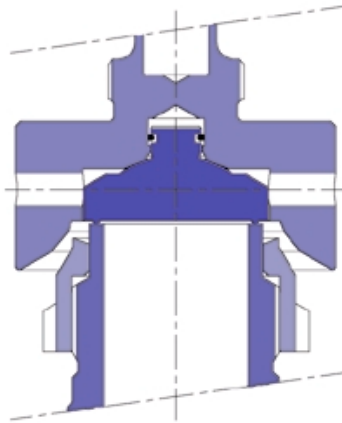

Liquid Trim Balanced Type 8190

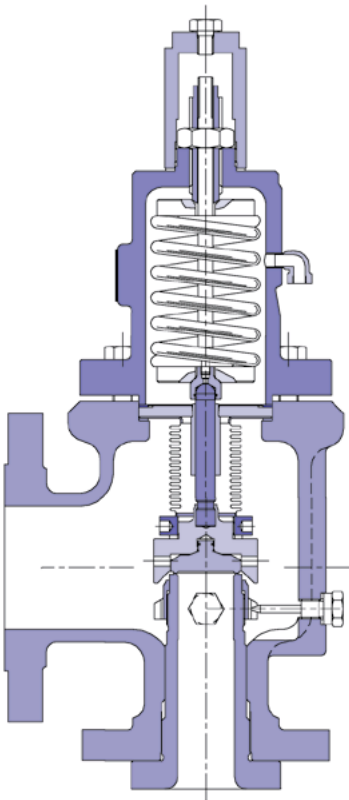

Liquid service type 8200/8290

The type 8200 has been developed from the type 8100 for full liquid relief applications. The patented flow profile of the trim allows the valve to go to full lift at 10% overpressure and eliminates the risk of chattering or hammering often observed when using ordinary safety relief valves on liquid application. No dampening device is required.

The certified flow coefficient at not more than 10% overpressure is $KD=0.799$. This very high value allows significant saving in valve sizing. In comparison, a non-certified valve sized according to API 520 would be affected by a flow coefficient of 0.62 multiplied by an overpressure factor of 0.6.

Liquid trim should be applied to full liquid operation, two phase flow or when flashing occurs. The type 8290 is a balanced bellows version of the liquid trim design.

Balanced bellows type 8190

Balanced bellows safety relief valves shall be used in either of the two following cases :

1. When a valve discharges into a closed system, a variable back pressure (for example due to the relief of another valve discharging into the same header) can occur. This superimposed variable back pressure needs to be balanced in order to avoid unstable valve operation. However a built up back pressure not exceeding 10% of the set pressure is generally considered acceptable with a non balanced (conventional) design.
2. When the valve is handling an aggressive or corrosive fluid and it is desirable to protect the upper part and mechanism of the valve against the medium. The bellows then acts as a chemical shield.

The type 8190 is a truly balanced bellows valve, i.e. the effective area of the bellows is equal to the seating area of the disc, thus allowing the valve to have an opening pressure independent from the back pressure.

In order to get truly balanced valves in the small sizes (orifices "D" and "E"), SAPAG offers as a standard a larger orifice size ("F") with a restricted lift to compensate and flow a "D" or "E" orifice size flow rate, respectively.

All balanced bellows valves must have their bonnet vented to atmosphere to remain truly balanced.

Standard bellows are 316L stainless steel; other materials such as INCONEL or MONEL are also available.

A conventional 8100 valve can be converted into a balanced 8190 with a minimum number of additional components.

Soft seated type 8110/8180

'O' Ring seat seal:

The 8110 soft seated safety relief valve design combines a metal to metal seat to absorb the spring load between the disc and the nozzle, and a 'O' Ring resilient soft seal. The design of the soft seal housing is such that the system pressure maintains the 'O' Ring on the seating surface, thus improving the tightness of the valve, even at a pressure very close to the set pressure.

The 8110 soft seated construction is particularly recommended in the following applications:

- where a tightness better than metal to metal is required
- when the operating pressure is more than 92% of the set pressure.
- when handling fugitive, corrosive or soiled media (with an appropriate selection of the 'O' Ring material);
- when the valve is used on vessels operating normally under vacuum, to avoid the penetration of atmospheric air into the system.
- when the system generates vibrations and pressure transients very close to the set pressure.

A 8100 valve can easily be converted into a 8110 soft seated version.

The type 8180 is a soft seated balanced bellows safety relief valve.

Types 8110 and 8180 are available in class Cl.150 and Cl.300 corresponding to model number 8111/8181 and 8113/8183, respectively.

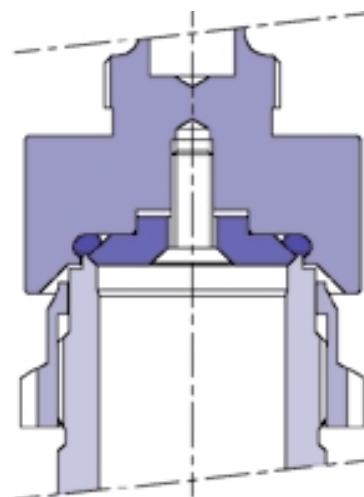

Detail of 'O' Ring seat design option

PTFE Soft seated valves for cryogenic applications

For cryogenic service, a PTFE soft seated version has been developed of the 8110/8180 series; this model consists of a valve where the regular disc has been replaced by a solid virgin PTFE plug. This design is particularly suitable for Liquid Natural Gas service and guarantees premium tightness performance after many valve operations. This design is limited to moderate pressure values.

Soft seat material selection

Extreme attention is drawn on a proper selection of the soft material to use. Such parameters are :

- compatibility of the soft material with the medium ;
- soft material temperature limitation in continuous service ;
- aging of the soft material in the medium at the service temperature

These issues must be taken into careful consideration. No one knows the behavior of soft material in the fluid better than the user whom needs to be consulted prior to the final selection. Most of the applications are covered by Fluorocarbon (VITON®) 'O' Rings as indicated on the following table. The manufacturer designation refers to the valve codification system, see Page 11. For special applications or other soft goods, consult the factory.

Soft good selection table

Soft seat material	SAPAG designation	Typical application	Temperature range
Fluorocarbon	code «P»	General	-25 to +200°C
Kalrez®	code «V»	Severe service	max. 280°C
EPT	code «K»	Steam	Saturation
PTFE	code «R»	LNG	cryogenic
Nitrile	code «T»	Hydrocarbon	-40 to +120°C

Note

Information on this table should be considered only as a guide. Compatibility of the selected material with the medium in service conditions has to be carefully considered by the user.

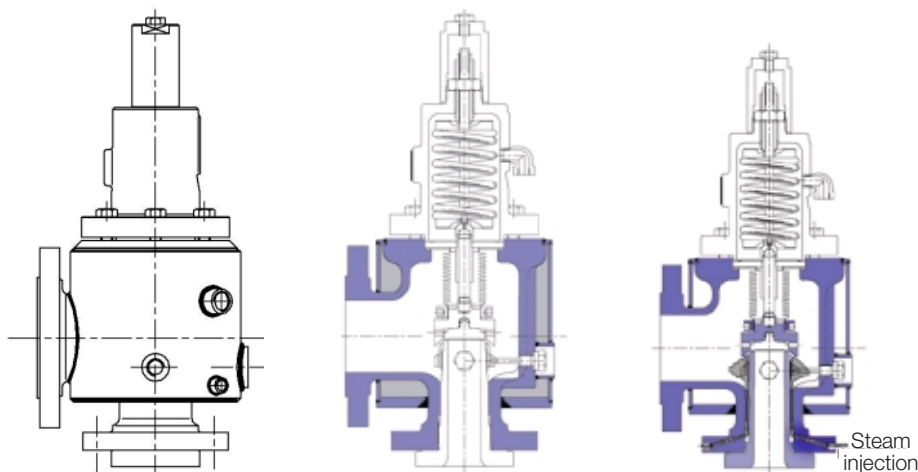

Steam jacket and steam injection

All series 8100 safety relief valves can be fitted with a steam heating jacket.

The steam jacket is hydrotested at 1.5 times the design pressure inside the heating system. Jacket connections are threaded or flanged. The steam jacket is normally fitted with an inlet and outlet connection and a drain plug.

Steam injection nozzles can be fitted on the body of the valves. The purpose of the steam injection is to "wash" continuously the seating area of the valve in order to prevent icing or solidification of the medium.

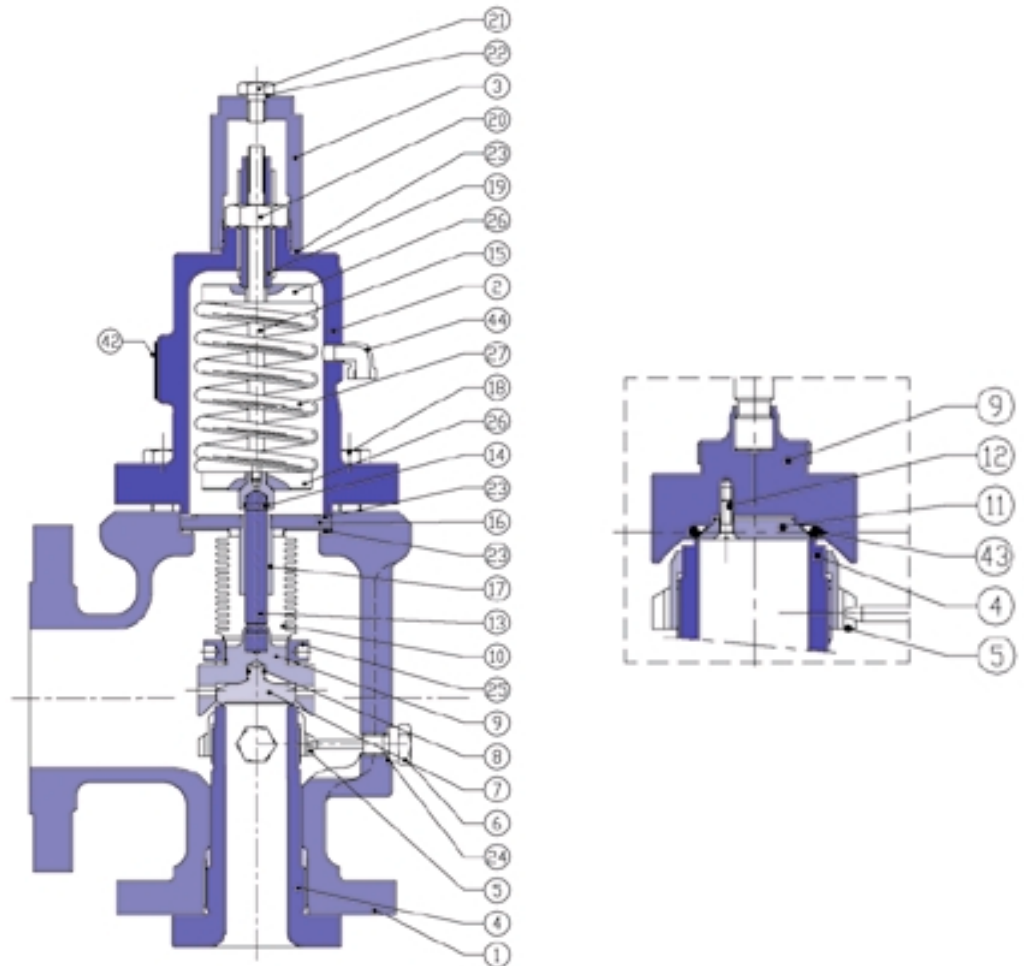

Standard materials

Construction Rep. Part name	Standard	WCB-2	Low temperature	L3
	WCB-1 -29 to +300°C -20 to +572°F	+301 to +427°C +573 to +800°F	LCB above -47°C above -53°F	down to -270°C down to -460°F
1 Body	SA216 WCC	SA216 WCC	SA352 LCC	SA351 CF8
2 Bonnet	SA216 WCC	SA216 WCC	SA352 LCC	SA351 CF8
3 Cap	Steel	Steel	Steel	316 SS
4 Nozzle	316LSS	316LSS	316LSS	316LSS
5 Adjusting Ring	AISI 431	AISI 431	AISI 431	316 SS
6 Adjusting Ring PIN	316 SS	316 SS	316 SS	316 SS
7 Disc	316LSS	316LSS	316LSS	316LSS
8 Disc Retainer	INCONEL	INCONEL	INCONEL	INCONEL
9 Disc Holder	316 SS	316 SS	316 SS	316 SS
10* Bellows	316LSS	316LSS	316LSS	316LSS
11** "O" Ring Retainer	316 SS	316 SS	316 SS	316 SS
12** Retainer Lock Screw	316 SS	316 SS	316 SS	316 SS
"O" Ring	To be specified	To be specified	To be specified	To be specified
13 Spindle Head	AISI 431	AISI 431	AISI 431	AISI 660
14 Spindle Retainer	INCONEL	INCONEL	INCONEL	INCONEL
15 Spindle	AISI 410	AISI 410	AISI 410	316 SS
16 Guide Flange	Steel	Steel	Steel	316 SS
17 Guide	316LSS	316LSS	316LSS	316LSS
18 Bonnet Screw	SA193 B7	SA193 B7	SA193 B7	SA193 B8
19 Adjusting Screw	AISI 410	AISI 410	AISI 410	316 SS
20 Adjusting Screw Nut	Steel	Steel	Steel	316 SS
21 Cap Plug	Steel	Steel	Steel	316 SS
22 Cap Plug Gasket	ARMCO Iron	ARMCO Iron	ARMCO Iron	Graphite 316SS
23 Gaskets	Impregnated Fiber	Impregnated Fiber	Impregnated Fiber	Impregnated Fiber
24 Adjusting Ring Pin Gasket	ARMCO Iron	ARMCO Iron	ARMCO Iron	Graphite 316SS
25* Bellows Gasket	Graphite 316SS	Graphite 316SS	Graphite 316SS	Graphite 316SS
26 Spring Washer	Steel	Steel	Steel	316 SS
27 Spring	Alloy Steel	Tungsten Steel	Alloy Steel	Stainless St.

* Series 8190/8290 Balanced Bellows only

** Series 8110/8180 Soft seated only

Safety Relief Valve Series 8100/8200

materials of construction

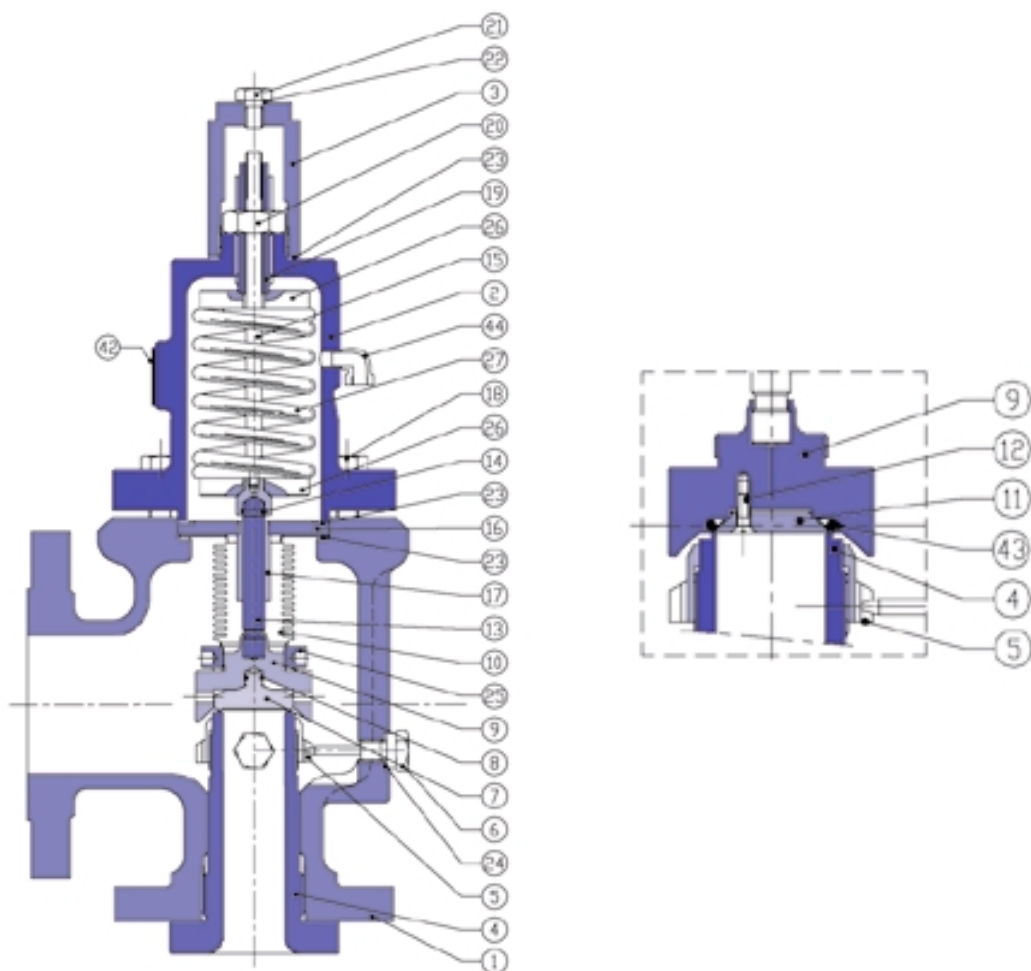

Standard materials

Construction Rep. Part name	Steam service, open bonnet		Steam service, closed bonnet		High temperature service	
	V0 up to 300°C up to 572°F	V3 up to 427°C up to 800°F	V1 up to 300°C up to 572°F	V2 up to 427°C up to 800°F	WC6 up to 538°C up to 1000°F	T2 (open bonnet) up to 815°C up to 1500°F
1 Body	SA216 WCC	SA216 WCC	SA216 WCC	SA216 WCC	SA217 WC6	SA351 CF8M
2 Bonnet	SA216 WCC	SA216 WCC	SA216 WCC	SA216 WCC	SA217 WC6	SA351 CF8M
3 Cap	Steel	Steel	Steel	Steel	Steel	316 SS
4 Nozzle	316LSS	316LSS	316LSS	316LSS	316LSS	310 SS
5 Adjusting Ring	AISI 431	AISI 431	AISI 431	AISI 431	AISI 431	310 SS
6 Adjusting Ring PIN	316 SS	316 SS	316 SS	316 SS	316 SS	316 SS
7 Disc	316LSS	High Temp Alloy St.	High Temp Alloy St.	High Temp Alloy St.	316LSS	310 SS
8 Disc Retainer	INCONEL	INCONEL	INCONEL	INCONEL	INCONEL	INCONEL
9 Disc Holder	316 SS	316 SS	316 SS	316 SS	316 SS	310 SS
10* Bellows	not available	not available	316LSS	316LSS	316LSS	not available
11 "O" Ring Retainer	not available	not available	not available	not available	not available	not available
12 Retainer Lock Screw	not available	not available	not available	not available	not available	not available
"O" Ring	not available	not available	not available	not available	not available	not available
13 Spindle Head	AISI 431	AISI 431	AISI 431	AISI 431	AISI 431	AISI 660
14 Spindle Retainer	INCONEL	INCONEL	INCONEL	INCONEL	INCONEL	INCONEL
15 Spindle	AISI 410	AISI 410	AISI 410	AISI 410	AISI 410	AISI 410
16 Guide Flange	Steel	Steel	Steel	Steel	Steel	310 SS
17 Guide	316LSS	MONEL	MONEL	MONEL	316LSS	310 SS
18 Bonnet Screw	SA193 B7	SA193 B7	SA193 B7	SA193 B7	SA193 B7	SA193 B8
19 Adjusting Screw	AISI 410	AISI 410	AISI 410	AISI 410	AISI 410	316 SS
20 Adjusting Screw Nut	Steel	Steel	Steel	Steel	Steel	Steel
21 Cap Plug	Steel	Steel	Steel	Steel	Steel	Steel
22 Cap Plug Gasket	ARMCO Iron	ARMCO Iron	ARMCO Iron	ARMCO Iron	ARMCO Iron	Graphite 316SS
23 Gaskets	Impregnated Fiber	Impregnated Fiber	Impregnated Fiber	Impregnated Fiber	Impregnated Fiber	Impregnated Fiber
24 Adjusting Ring Pin Gasket	ARMCON Iron	ARMCON Iron	ARMCON Iron	ARMCON Iron	ARMCON Iron	Graphite 316SS
25* Bellows Gasket	Not available	Not available	Graphite 316SS	Graphite 316SS	Graphite 316SS	not available
26 Spring Washer	Steel	Steel	Steel	Steel	Steel	316 SS
27 Spring	Alloy Steel	Alloy Steel	Alloy Steel	Tungsten Steel	Tungsten Steel	Tungsten Steel

* Series 8190/8290 Balanced bellows only

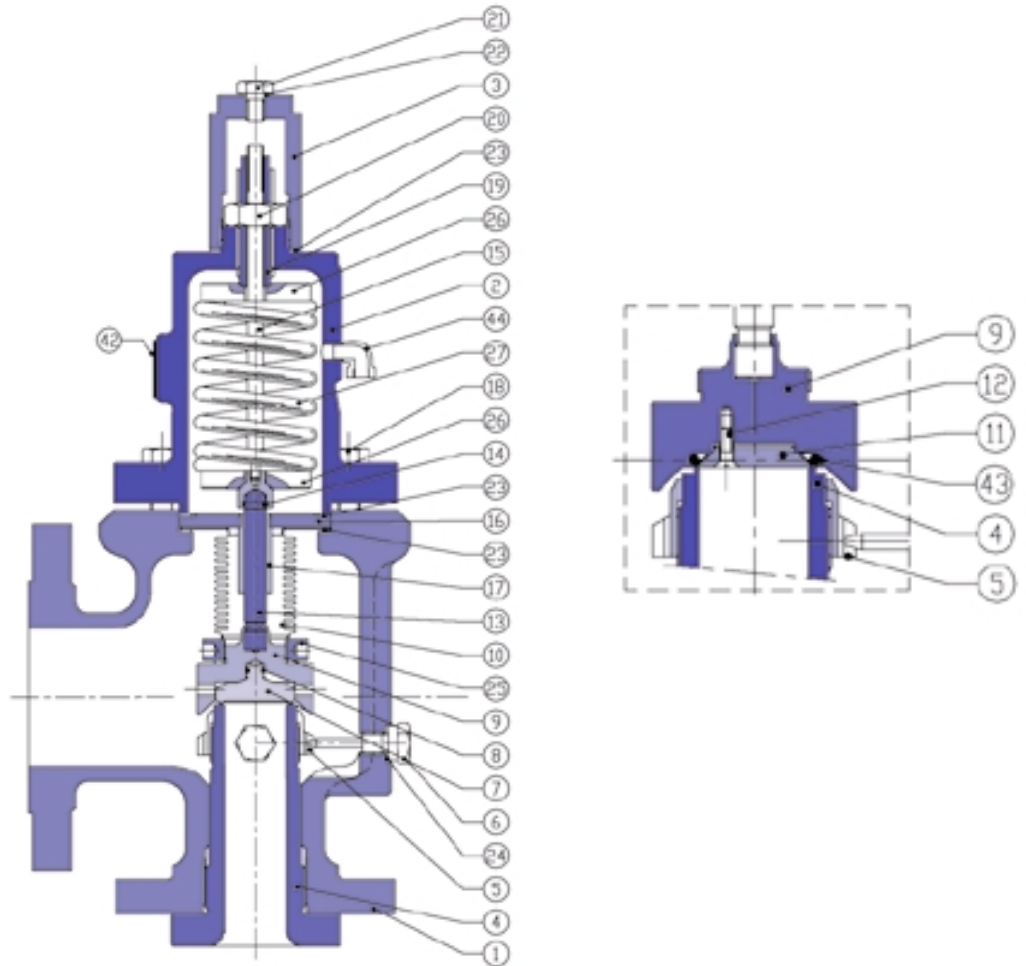

Standard materials

Construction

Sour Gas Service, NACE MR0175

Rep.	Part Name	Without bellows (8100)		With bellows (8190)	
		S2M	SGM	S2M	SGM
1	Body	SA216 WCC	SA216 WCC	SA216 WCC	SA216 WCC
2	Bonnet	SA216 WCC	SA216 WCC	SA216 WCC	SA216 WCC
3	Cap	Steel	Steel	Steel	Steel
4	Nozzle	316LSS	316LSS	316LSS	316LSS
5	Adjusting Ring	316 SS	316 SS	316 SS	316 SS
6	Adjusting Ring Pin	316 SS	316 SS	316 SS	316 SS
7	Disc	316LSS	High Temp Alloy St.	High Temp Alloy St.	High Temp Alloy St.
8	Disc Retainer	INCONEL	INCONEL	INCONEL	INCONEL
9	Disc Holder	316 SS	316 SS	316 SS	316 SS
10*	Bellows	not available	not available	316 SS	INCONEL
11**	"O" Ring Retainer	316 SS	316 SS	316 SS	316 SS
12**	Retainer Lock Screw	316 SS	316 SS	316 SS	316 SS
	"O" Ring	To be specified	To be specified	To be specified	To be specified
13	Spindle Head	AISI 660	AISI 660	AISI 660	AISI 431
14	Spindle Retainer	INCONEL	INCONEL	INCONEL	INCONEL
15	Spindle	AISI 410	316 SS	AISI 410	AISI 410
16	Guide Flange	Steel	316 SS	Steel	Steel
17	Guide	316LSS	316LSS	316LSS	316LSS
18	Bonnet Screw	SA193 B7	SA193 B7M	SA193 B7	SA193 B7M
19	Adjusting Screw	AISI 410	316 SS	AISI 410	AISI 410
20	Adjusting Screw Nut	Steel	Steel	Steel	Steel
21	Cap Plug	Steel	Steel	Steel	Steel
22	Cap Plug Gasket	ARMCO Iron	ARMCO Iron	ARMCO Iron	ARMCO Iron
23	Gaskets	Impregnated Fiber	Impregnated Fiber	Impregnated Fiber	Impregnated Fiber
24	Adjusting Ring Pin Gasket	ARMCON Iron	ARMCON Iron	ARMCON Iron	ARMCON Iron
25*	Bellows Gasket	Not available	Not available	Graphite 316SS	Graphite 316SS
26	Spring Washer	Steel	316 SS	Steel	316SS
27	Spring	Aluminised Steel	INCONEL	Aluminised Steel	Aluminised Steel

* Series 8190/8290 Balanced Bellows only

** Series 8110/8180 Soft seated only

Safety Relief Valve Series 8100/8200

materials of construction

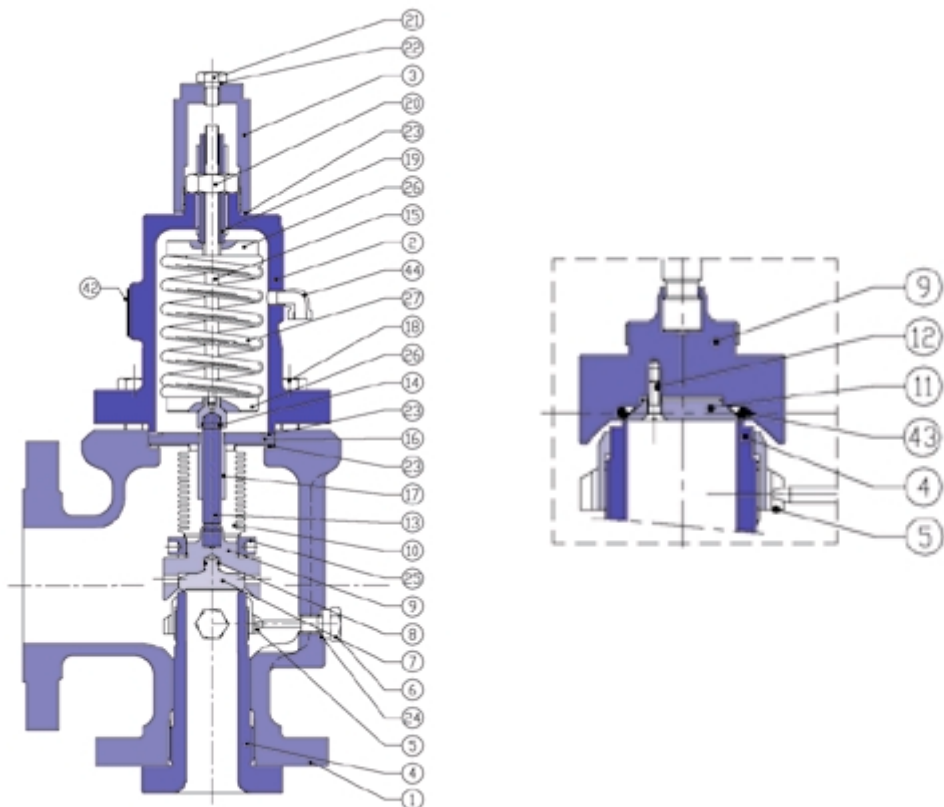

Standard materials

Construction		Corrosive service			
		S3M	S4M	S5M	M1
Rep.	Part Name	All stainless except spring	All stainless only	With bellows (8190)	MONEL (or other alloys)
1	Body	SA351 CF8M	SA351 CF8M	SA351 CF8M	SA216 WCC
2	Bonnet	SA351 CF8M	SA351 CF8M	SA216 WCC	SA216 WCC
3	Cap	316 SS	316 SS	Steel	Steel
4	Nozzle	316LSS	316LSS	316LSS	MONEL
5	Adjusting Ring	316 SS	316 SS	316 SS	Std
6	Adjusting Ring Pin	316 SS	316 SS	316 SS	Std
7	Disc	316LSS	316LSS	316LSS	MONEL
8	Disc Retainer	INCONEL	INCONEL	INCONEL	INCONEL
9	Disc Holder	316 SS	316 SS	316 SS	316 SS
10*	Bellows	316 SS	316 SS	316 SS	316 SS
11**	"O" Ring Retainer	316 SS	316 SS	316 SS	316 SS
12**	Retainer Lock Screw	316 SS	316 SS	316 SS	316 SS
	"O" Ring	To be specified	To be specified	To be specified	To be specified
13	Spindle Head	AISI 660	AISI 660	AISI 431	AISI 431
14	Spindle Retainer	INCONEL	INCONEL	INCONEL	INCONEL
15	Spindle	316 SS	316 SS	AISI 410	AISI 410
16	Guide Flange	316 SS	316 SS	Steel	Steel
17	Guide	316LSS	316LSS	316LSS	316LSS
18	Bonnet Screw	SA193 B8	SA193 B8	SA193 B7	SA193 B7
19	Adjusting Screw	316 SS	316 SS	AISI 410	AISI 410
20	Adjusting Screw Nut	316 SS	316 SS	Steel	Steel
21	Cap Plug	316 SS	316 SS	Steel	Steel
22	Cap Plug Gasket	Graphite 316SS	Graphite 316SS	ARMCO Iron	ARMCO Iron
23	Gaskets	Impregnated Fiber	Impregnated Fiber	Impregnated Fiber	Impregnated Fiber
24	Adjusting Ring Pin Gasket	Graphite 316SS	Graphite 316SS	ARMCON Iron	ARMCON Iron
25*	Bellows Gasket	Graphite 316SS	Graphite 316SS	Graphite 316SS	Graphite 316SS
26	Spring Washer	316 SS	316 SS	Steel	Steel
27	Spring	Nickel Plated Steel	Stainless Steel	Alloy Steel	Alloy Steel

* Series 8190/8290 Balanced Bellows only

** Series 8110/8180 Soft seated only

Other constructions

SA351 CF3 : construction S3L, S4L (with SS spring)
 SA351 CF3M : construction S3D, S4D (with SS spring)
 SA351 CF8 : construction S3, L3 (with SS spring)
 All MONEL but spring : M3
 All MONEL : M4

Lifting device Options

Plain (type C) or packed (type E or F) lifting devices are available on all types of valves. Remote air actuated lifting devices (Pneumatic actuator type P) are also available.

Plain Type C lever (threaded)

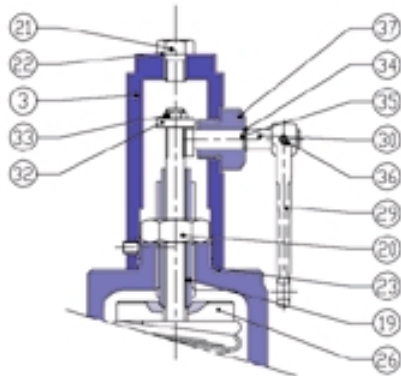

Packed Type F Lever (threaded)

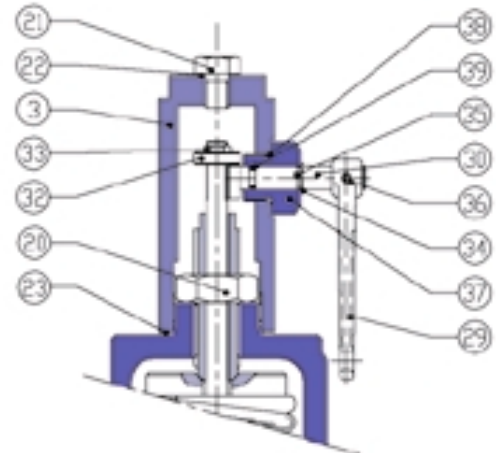

**Test Gag
(standard feature - all cap types)**



**Packed Type E Lever
(bolted)**

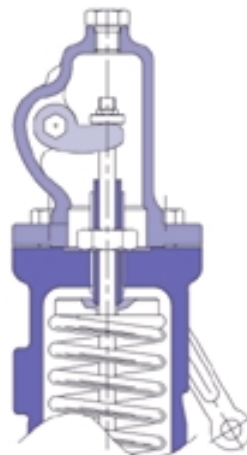

Pneumatic Actuator Type P

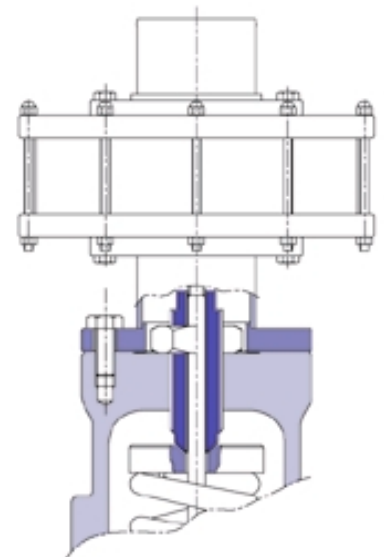

Test gag

All Sapag safety relief valves are fitted with a test gag on top of the cap as standard. This gag is in place during transportation to avoid damaging the seating surfaces. When the gag is in place, the valve is locked in the closed position. For testing please refer to maintenance manual.

IMPORTANT

The test gag is clearly identified by a RED TAG attached to it specifying that it MUST be removed and replaced by the plug and gasket (supplied) before valve operation. It is advised that the gag is removed just after erection on site.

Lifting mechanism

Rep.	Lever type "C"	WCB, LCB, V0-1-2-3	L3, T2, S3M, S4M,
		WC6, S2M, SGM, S5M, M1	M3, M4, S3X, S4X
29	Lever	Steel	Stainless Steel
30	Shaft	AISI 410	316 SS
31	Fork	Steel	Stainless Steel
32	Washer	AISI 410	316 SS
33	Jam nut	AISI 410	316 SS
34	Retaining ring	AISI 410	Stainless Steel
35	Elastic ring	Inconel	Inconel
36	Pin	Steel	Stainless Steel
37	Stuffing box	Steel	316 SS
Lever type "F"			
29	Lever	Steel	Stainless Steel
30	Shaft	AISI 410	316 SS
31	Fork	Steel	Steel
32	Washer	AISI 410	316 SS
33	Jam nut	AISI 410	316 SS
34	Retaining ring	AISI 410	Stainless Steel
35	Elastic ring	Inconel	Inconel
36	Pin	Steel	Stainless Steel
37	Stuffing box	Steel	316 SS
38	Gasket	ARMCO Iron	Stainless Steel
39	O'Ring	Nitrile	Nitrile

Safety Relief Valve Series 8100/8200

dimensions

Sizes, weights and dimensions

Size & Class	Orifice	Type	A	B	C	S	WT
			mm	mm	mm	mm	kg
1"-150 x 2"-150"	D,E	8101, 8191	104,8	114,3	418	32	15
1"-300 x 2"-150"		8102, 8192	104,8	114,3	418	35	15
1"-300 x 2"-150"		8103, -93, -23, -53	104,8	114,3	418	35	16
1"-600 x 2"-150"		8104, -94, -24, -54	104,8	114,3	418	35	16
1 1/2"-900 x 2"-300"		8106, -96, -26, -56	104,8	139,7	440	49	28
1 1/2"-1500 x 2"-300"		8107, -97, -27, -57	104,8	139,7	440	49	28
1 1/2"-2500 x 2 1/2"-300"		8108, -98, -28, -58	139,7	165,1	660	62	55
1 1/2"-2500 x 3"-300"		Z 8108, -98, -28, -58	139,7	177,8	660	62	60
1 1/2"-150 x 2"-150"	F	8101, 8191	123,8	120,6	432	35	18
1 1/2"-300 x 2"-150"		8102, 8192	123,8	120,6	432	38	18
1 1/2"-300 x 2"-150"		8103, -93, -23, -53	123,8	152,4	432	38	21
1 1/2"-600 x 2"-150"		8104, -94, -24, -54	123,8	152,4	454	40	23
1 1/2"-900 x 2 1/2"-300"		8106, -96, -26, -56	123,8	152,4	576	49	36
1 1/2"-1500 x 2 1/2"-300"		8107, -97, -27, -57	123,8	152,4	576	49	36
1 1/2"-2500 x 2 1/2"-300"		8108, -98, -28, -58	139,7	165,1	565	62	55
1 1/2"- 900 x 3"-300"		Z 8106, -96, -26, -56	123,8	165,1	576	49	40
1 1/2"-1500 x 3"-300"		Z 8107, -97, -27, -57	123,8	165,1	576	49	40
1 1/2"- 2500 x 3"-300"		Z 8108, -98, -28, -58	139,7	177,8	576	62	59
1 1/2"-150 x 2 1/2"-150"	G	8101, 8191	123,8	120,6	432	35	21
1 1/2"-300 x 2 1/2"-150"		8102, 8192	123,8	120,6	432	38	21
1 1/2"-300 x 2 1/2"-150"		8103, -93, -23, -53	123,8	152,4	432	38	23
1 1/2"-600 x 2 1/2"-150"		8104, -94, -24, -54	123,8	152,4	454	40	25
1 1/2"-900 x 2 1/2"-300"		8106, -96, -26, -56	123,8	152,4	577	49	36
2"-1500 x 3"-300 "		8107, -97, -27, -57	155,6	171,5	610	56	36
2"-2500 x 3"-300"		8108, -98, -28, -58	155,6	171,5	610	68	40
1 1/2"-150 x 3"-150"		Z 8101, 8191	123,8	120,6	432	35	23
1 1/2"-300 x 3"-150"		Z 8102, 8192	123,8	120,6	432	38	23
1 1/2"-300 x 3"-150"		Z 8103, -93, -23, -53	123,8	152,4	432	38	25
2"-600 x 3"-150"		Z 8104, -94, -24, -54	123,8	152,4	454	40	27
2"-900 x 3"-300"		Z 8106, -96, -26, -56	123,8	165,1	577	49	40
1 1/2"-150 x 3"-150"	H	8101, 8191	130,2	123,8	455	35	23
1 1/2"-300 x 3"-150"		8102, 8192	130,2	123,8	455	38	23
2"-300 x 3"-150"		8103, -93, -23, -53	130,2	123,8	480	40	25
2"-600 x 3"-150"		8104, -94, -24, -54	154	161,9	625	44	30
2"-900 x 3"-150"		8106, -96, -26, -56	154	161,9	625	48	48
2"-1500 x 3"-300 "		8107, -97, -27, -57	154	161,9	625	56	51
2"-150 x 3"-150"	J	8101, 8191	136,5	123,8	500	37	28
2"-300 x 3"-150"		8102, 8192	136,5	123,8	500	40	28
2 1/2"-300 x 4"-150"		8103, -93, -23, -53	136,5	123,8	620	44	36
2 1/2"-600 x 4"-150"		8104, -94, -24, -54	155,6	142,9	630	46	62
3"-900 x 4"x 150"		8106, -96, -26, -56	184,1	171,4	660	56	69
3"- 1500 x 4"-300"		8107, -97, -27, -57	184,1	181	730	65	80
3"-300 x 4"-150"		Z 8103, -93, -23, -53	184,1	181	660	44	65
3"-600 x 4"-150"		Z 8104, -94, -24, -54	184,1	181	660	46	67
3"-150 x 4"-150"	K	8101, 8191	155,6	161,9	635	42	40
3"-300 x 4"-150"		8102, 8192	155,6	161,9	635	46	40
3"-300 x 4"-150"		8103, -93, -23, -53	155,6	161,9	700	46	51
3"-600 x 4"-150"		8104, -94, -24, -54	184,1	181	730	49	55
3"-900 x 6"x 150"		8106, -96, -26, -56	198,4	215,9	780	56	110
3"-1500 x 6"-300"		8107, -97, -27, -57	196,8	215,9	780	65	125
3"-150 x 4"-150"	L	8101, 8191	155,6	165,1	695	42	51
3"-300 x 4"-150"		8102, 8192	155,6	165,1	695	46	52
4"- 300 x 6" - 150"		8103, -93, -23, -53	179,4	181	775	49	80
4"-600 x 6"-150"		8104, -94, -24, -54	179,4	203,2	785	56	82
4"-900 x 6"-150"		8106, -96, -26, -56	196,8	222,2	820	62	136
4"-1500 x 6"-300"		8107, -97, -27, -57	196,8	222,2	820	72	138
4"-150 x 6"-150"	M	8101, 8191	177,8	184,1	720	42	68
4"-300 x 6"-150"		8102, 8192	177,8	184,1	720	50	68
4"-300 x 6"-150"		8103, -93, -23, -53	177,8	184,1	780	50	82
4"-600 x 6"-150"		8104, -94, -24, -54	177,8	203,2	805	56	110
4"-900 x 6"-150"		8106, -96, -26, -56	196,8	222,2	825	62	130
4"-150 x 6"-150"	N	8101, 8191	196,8	209,5	810	42	80
4"-300 x 6"-150"		8102, 8192	196,8	209,5	810	50	60
4"-300 x 6"-150"		8103, -93, -23, -53	196,8	209,5	830	50	98
4"-600 x 6"-150"		8104, -94, -24, -54	196,8	222,2	920	56	136
4"-900 x 6"-150"		8106, -96, -26, -56	196,8	222,2	920	62	140
4"-150 x 6"-150"	P	8101, 8191	181	228,6	900	42	98
4"-300 x 6"-150"		8102, 8192	181	228,6	900	50	100
4"-300 x 6"-150"		8103, -93, -23, -53	225,4	254	995	50	132
4"-600 x 6"-150"		8104, -94, -24, -54	225,4	254	1095	56	204
4"-900 x 6"-150"		8106, -96, -26, -56	225,4	254	1095	62	206
6"-150 x 8"-150"	Q	8101, 8191	239,7	241,3	990	46	160
6"-300 x 8"-150"		8102, 8192	239,7	241,3	990	57	165
6"-300 x 8"-150"		8103, -93, -23, -53	239,7	241,3	1050	57	204
6"-600 x 8"-150"		8104, -94, -24, -54	239,7	241,3	1135	64	257
6"-150 x 8"-150"	R	8101, 8191	240	241	1040	46	195
6"-300 x 8"-150"		8102, 8192	240	241	1040	57	200
6"-300 x 10"-150"		8103, -93, -23, -53	240	267	1100	57	206
6"-600 x 10"-150"		8104, -94, -24, -54	240	267	1180	69	276
8"-150 x 10"-150"	T	8101, 8191	276,2	279,4	1075	50	253
8"-300 x 10"-150"		8102, -92, -22, -52	276,2	279,4	1155	62	276
8"-300 x 10"-150"		8103, -93, -23, -53	276,2	279,4	1275	62	320
10"-150 x 14"-150"	V	8101, 8191	380	370	1415	51	560
10"-300 x 14"-150"		8102, -92, -22, -52	380	370	1415	69	600
12"-150 x 12"x2 -150"	W	8101, 8191	327	430	1235	53	900
12"-300 x 12"x2 -300"		8102, -92, -22, -52	327	430	1235	72	950

Valve designation

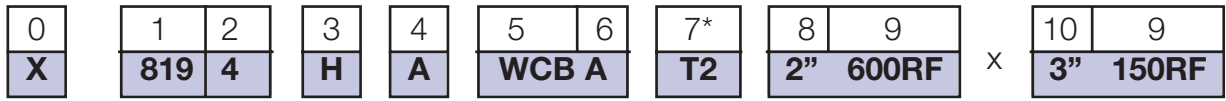

or

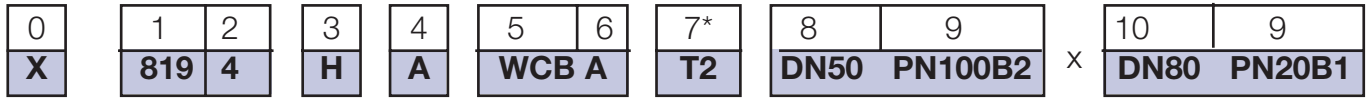

0 Optional additional digit for special features

- X: Additional device
- Y: Special material
- Z: Special machining.

1 Valve type

- 8100: Conventional
- 8110: Soft seated
- 8120: High temperature
- 8180: Soft seat and bellows
- 8190: Bellows
- 8200: Liquid trim
- 8290: Liquid trim and bellows

2 Pressure class

- 1: 150lbs or PN20
- 2: 300lbs or PN50 light series *
- 3: 300lbs or PN50
- 4: 600lbs or PN100
- 6: 900lbs or PN150
- 7: 1500lbs or PN250
- 8: 2500lbs or PN420
- * 150# body with an inlet flange machined to 300#

3 Orifice size

8100/8200 series:	D	H	M	R
	E	J	N	T
	F	K	P	V
	G	L	Q	W

4 Accessories

- A: Screwed cap
- C: Screwed cap and plain lever
- E: Bolted cap and packed lever
- F: Screwed cap and packed lever
- P: Remote air actuator

5 Material

WCB	SGM	M1	V3
LCB	S3M	V0	WC6
L3	S4M	V1	T2
S2M	S5M	V2	

6 Seating

- A: metal/metal
- D: stellited nozzle
- E: stellited nozzle and disc
- F: stellited disc
- K: EPT soft seat
- P: Fluorocarbon soft seat
- R: PTFE solid disc
- T: Nitrile soft seat
- V: Kalrez R soft seat

7 Spring material

Note: based on material availability, the factory reserves the right to offer a material better than specified.

* this digit is optional; when omitted, the spring material as per the standard bill of material and/or the specified service temperature will be offered.

- C: Carbon steel
- A: High temperature alloy steel
- S: Stainless steel
- PH: Precipitation hardened stainless steel
- X: High Nickel alloy
- K: Copper Nickel alloy
- T2: Tungsten high temperature alloy steel
- T9: High Tungsten alloy steel

8 Inlet NPS or DN

9 Inlet and outlet flange class and finish

10 Outlet NPS or DN