

SCHROEDAHL

we protect your business

Series TD

Type TDL

Type TDM

Automatic Recirculation Valve
for pump protection



Series TD

The SCHROEDAHL Automatic Recirculation Valve is utilized as a pump protection system for centrifugal pumps

Preamble

SCHROEDAHL is the largest supplier of Automatic Recirculation Valves in the world. These ARV's, or pump protection systems, are our principal products. During the last 45 years we have supplied more than 45,000 of these valves to satisfied customers all over the world.



Features:

- Automatic bypass operation
- Modulating functioning
- Low maintenance
- Easy to install
- Damping of system pulsations
- Suitable for all fluids
- Self operated
- Reduces plant investment and operational costs



Application

Automatic Recirculation Valves protect centrifugal pumps against overheating, excessive noise, instability and cavitation during low load conditions.

If the flow through the system falls below a certain level the bypass system at the valve opens and the fluid will be recirculated providing the required minimum flow through the pump.

Operation

The outlet main flow controls the check valve at a certain position. The stem of the check valve transmits the motion via a lever to the bypass. The bypass system regulates the bypass flow in a modulating way and reduces the pressure to bypass outlet level without cavitation. The full minimum flow is bypassed when the check valve is seated. The bypass is fully closed when the check valve is in its upper position, thereby allowing full pump flow to the system.

Fig.1: Drawing of an Automatic Recirculation Valve type TDM

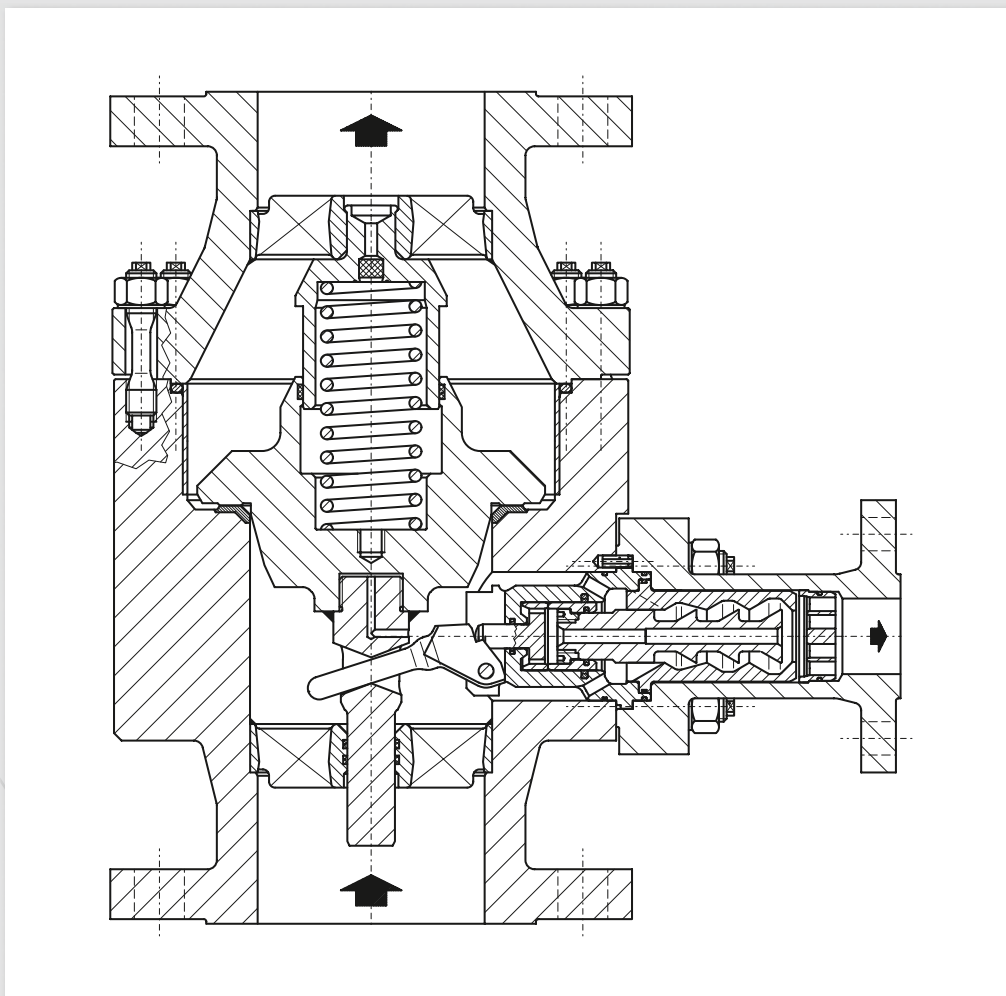

Operation of the Automatic Recirculation Valves

Flow sensitive

The check valve moves upwards with increasing main flow and downwards with decreasing flow. The check valve transmits this motion via a lever to the bypass system (Fig. 3 and 4).

Type TDL

The TDL consists of the check valve section (Fig. 2) with bypass configuration type L (Fig. 3). The lever controls the position of the bushing, which in turn opens more or less the holes in the control head. The minimum flow is thereby bypassed in a modulating way. Applicable for differential pressures up to 40 bar. Standard with non-return function.

Type TDM

The TDM consists of the check valve section (Fig. 2) with bypass configuration type M (Fig. 4). The movement of the lever is transmitted via a piston to the multi-stages vortex plug. The minimum flow is thereby bypassed in a modulating way over several pressure reduction stages.

Applicable for differential pressures from 20 bar up to 230 bar. Standard with non-return function.

Fig. 3: Bypass L

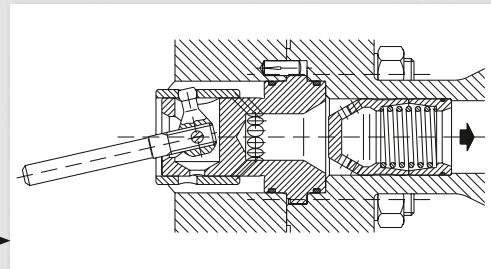

Fig. 4: Bypass M

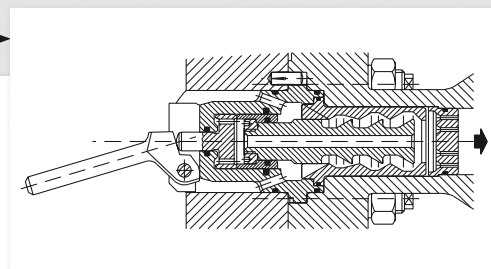
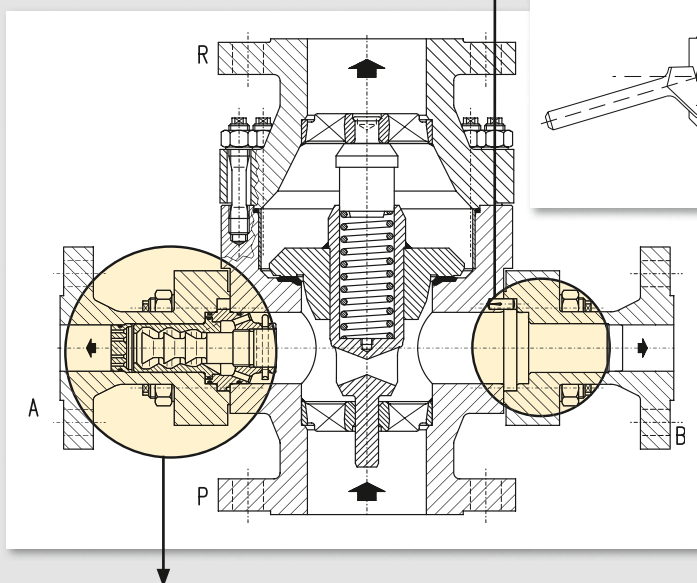

Fig. 2



Manual start-up or warm-up option with connection below the check valve.
The manual start-up or warm-up option can be added on request.

Valve sizes

Standard size from DN 25 (1") up to DN 300 (12").

Pressure rating

Pressure rating ranges from PN 10 up to PN 400 (150 lbs to 2500 lbs). Other ratings upon request.

Connections

Flanges are as a standard according DIN or ASME, Flanges according to other standards (DIN, ISO, BS, JIS, NF) are available upon request. The inlet and outlet connections can also be supplied with welding ends. The bypass connection is always flanged (for inspection purposes). Manual start up upon request. Draining or warm up connection are available.

Materials

Standard housing materials:
ASTM A105 (Carbon Steel), DIN 1.0460
ASTM 316L (Stainless Steel), DIN 1.4404

The standard internals of the TD valves are manufactured from stainless steel with a minimum chrome content of 13%. Other forged materials for housing and internals available upon request. Selection of the seal material is done according to medium and temperature condition. The housing material is selected according to medium, pressure and temperature condition.

Size-Code		Pressure class-Code		Connection-Code	Configuration-Code
DN 1"	= 05	150	= 3	U = Flanges acc. ASME	V = Vertical Installation
DN 1¼"	= 06	300	= 5	S = Welding Ends	H = Horizontal Installation
DN 1½"	= 07	600	= 6	J = JIS	A = Manual Start-up
DN 2"	= 08	900	= 7	B = BS	W = Oversized Bypass or Start-up Connection
DN 2½"	= 09	1500	= 8		CS = Carbon Steel
DN 3"	= 10	2500	= 0		ASTM A105
DN 4"	= 11				SS = Stainless Steel
DN 5"	= 12				ASTM 316L
DN 6"	= 13				
DN 8"	= 15				
DN 10"	= 16				
DN 12"	= 17				

Example:

TDM116UWV-CS: Valve type TDM; 4", class 600, ASME-Flanges, vertical installation, housing material in carbon steel

Parts list

Housing

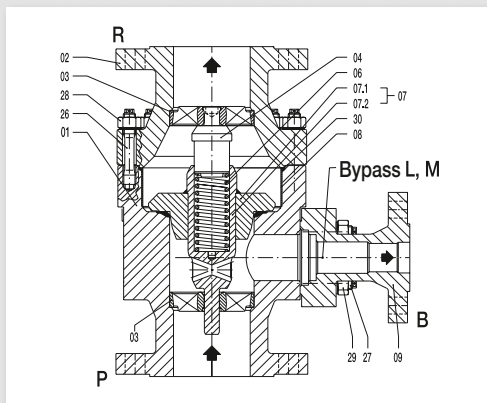

Bypass L

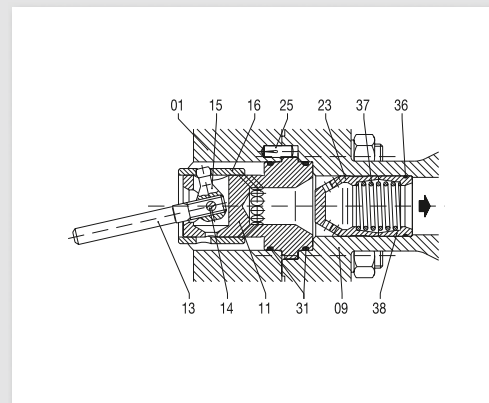

Housing assembly

Pos.	Description
01	Lower Body
02	Upper Body
03	Stemguide
04	Guide Bolt
06	Spring
07	Check Valve
07.1	Check Valve
07.2	Stem
08	Liner or Venturi-Ring
09	Bypass Branch
25	Guide Pin
26	Bolt
27	Bolt
28	Hexagon Nut
29	Hexagon Nut
30	O-Ring

Bypass L

Pos.	Description
11	Control Head
13	Lever
14	Pivot Pin
15	Crank Arm
16	Control Bushing
23	Orifice Bushing
31	O-Ring
36	O-Ring
37	Spring
38	Bottom Ring

Bypass M

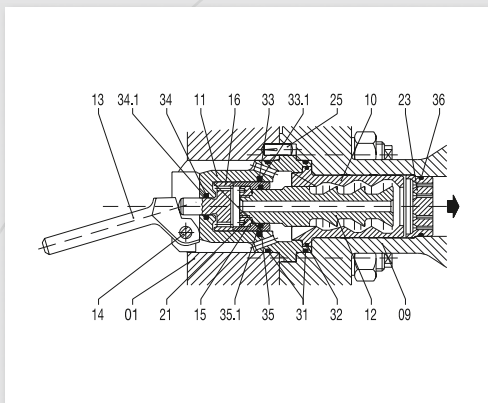

Manual Startup

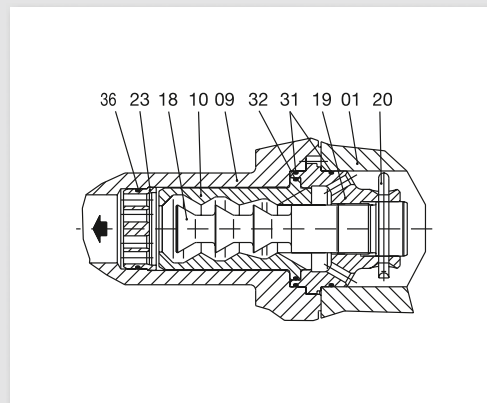

Bypass M

Pos.	Description
10	Vortex Bushing
11	Control Head
12	Vortex Plug
13	Lever
14	Pivot Pin
15	Relief Bushing
16	Relief Piston
21	Threaded Ring
23	Bypass Orifice
31	O-Ring
32	O-Ring
33	O-Ring
33.1	Glyd-Ring
34	O-Ring
34.1	Glyd-Ring
35	O-Ring
35.1	Glyd-Ring
36	O-Ring

Manual Start-up

Pos.	Description
10	Vortex Bushing
18	Vortex Pug
19	Holder
20	Pin
23	Orifice Plate
31	O-Ring
32	O-Ring
36	O-Ring

Sizing and selection

Nominal size and pressure class of the Automatic Recirculation Valve should be selected preferably the same as the outlet of the pump.

Notes

The following table is only to be used as an indication. Other bypass sizes available upon request. For final valve selection please contact our office.

Size-Code	05	06	07	08	09	10	11	12	13	15	16	17
DN P, R (mm)	25	32	40	50	65	80	100	125	150	200	250	300
DN P, R (inch)	1	1¼	1½	2	2½	3	4	5	6	8	10	12
Main flow P,R for TDL and TDM valves (m³/h)	16	26	40	56	84	124	200	310	445	790	1240	1780
Bypass L / M DN (mm)	25	25	25	25	40	40	50	50	65	80	100	125
see Fig.3/4 DN (inch)	1	1	1	1	1½	1½	2	2	2½	3	4	5
Bypass flow P-B (m³/h)	18	18	18	18	40	40	64	64	120	180	280	432

Example valve selection:

$$K_v = Q_{\min} \times \sqrt{\frac{s.g.}{\Delta p}}$$

Q_{\min} = Minimum flow in m³/h, s.g. specific gravity in kg/dm³
 Δp = differential pressure in bar over the bypass at minimum flow

Conditions: DN 100 pump, PN 100, main flow is 180 m³/h, required bypass flow is 40 m³/h, s.g. is 0.95 kg/dm³, Δp is 70 bar at Q_{\min} .

- Selection:
- The main flow is in range of a DN 100 valve
 - The Δp at minimum flow is ≥ 40 bar, this means that we have to select a valve type TDM.
 - $K_v = 40 \times \sqrt{0.95 / 70} = 4.8$, this means a DN 100 valve with a DN 50 bypass can be used as the maximum K_v is 5.4 m³/h

Installation Rules

The Automatic Recirculation Valve should be installed as close as possible to the centrifugal pump, preferably directly on the outlet of the pump. To prevent low frequency shocks caused by pulsation of the medium, the distance between pump outlet and valve inlet should not exceed 2 m. Vertical installation is preferred, but horizontal installation is also possible on request. The TDL and TDM valves operate at a low noise level and ensure a high reliability due to their sturdy design. The recommended filter should have a max. mesh size of 0.3 to 0.5 mm.

For commissioning we also recommend smaller filter mesh size.

Maintenance

Maintenance and installation instructions are available upon request or at www.schroedahl.com. Valve test run is recommended together with pump test run/ function test, with the usual operational test of the pump.



Automatic Recirculation Valve Technical Data

Customer:

Enquiry no.:

Prior reference:

Order no.:

Project:

Datasheet:

Quantity:

Automatic Recirculation Valve type:

Valve inlet [in.]	DN	<input type="text"/>	PN	<input type="text"/>	Acc.: <input type="text"/>
Valve outlet [in.]	DN	<input type="text"/>	PN	<input type="text"/>	Installation: <input type="checkbox"/> vertical <input type="checkbox"/> horizontal
Bypass outlet [in.]	DN	<input type="text"/>	PN	<input type="text"/>	Paint: <input type="text"/>
Start-up [in.]	DN	<input type="text"/>	PN	<input type="text"/>	Start-up <input type="checkbox"/> above <input type="checkbox"/> below checkvalve

Mat.-/test certificates:

Materials:

Housing: Internals: Seals:

Medium: Operating temp. [°C]:

S.G. [kg/m³]: Design temp. [°C]:

$Q_M =$ <input type="text"/> m³/h	$H_0 =$ <input type="text"/> m	Suction pr. p_v <input type="text"/> bar
$Q_{100} =$ <input type="text"/> m³/h	$H_M =$ <input type="text"/> m	Differential pr. ($p_1 - p_v$) <input type="text"/> bar
$Q_{max} =$ <input type="text"/> m³/h	$H_{100} =$ <input type="text"/> m	Backpress p_N <input type="text"/> bar
$Q_A =$ <input type="text"/> m³/h	$H_A =$ <input type="text"/> m	Backpress p_A <input type="text"/> bar

Notes:

Revision	Date	Description	Name	Signature

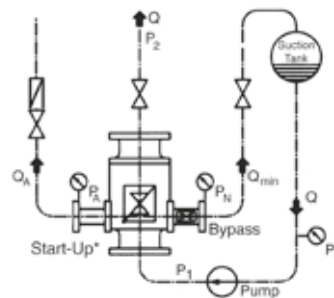
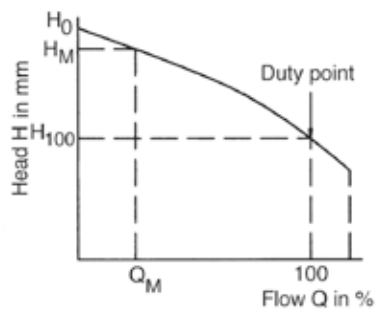

Dimensions

DIN

Size	DN _R /DN _P	PN	DN _B	L (mm)	S (mm)	H (mm)	Weight (kg)
051-052-053-054	25	10-16-25-40	25	190	153	73	15
055		63		250	182	90	32
056		100		250	182	90	32
061-062-063-064	32	10-16-25-40	25	190	153	73	17
065		63		250	182	90	30
066		100		300	182	90	30
071-072-073-074	40	10-16--25-40	25	200	155	75	19
075-076-077		63-100-160		260	190	90	34
078		250		300	215	120	47
081-082-083-084	50	10-16-25-40	25	230	163	90	26
085		63		300	185	115	47
086-087		100-160		300	193	110	56
088		250		350	223	130	85
091-092-093-094	65	10-16-25-40	40	290	184	110	37
095		63		340	219	125	56
096-097		100-160		340	227	125	83
098		250		400	260	145	89
101-102-103-104	80	10-16-25-40	40	310	192	115	48
105		63		380	233	140	69
106-107		100-160		380	240	140	85
108		250		450	265	165	125
111-112-113-114	100	10-16-25-40	50	350	221	125	72
115		63		430	258	155	105
116-117		100-160		430	266	155	150
118		250		520	300	190	200
121-122-123-124	125	10-16-25-40	50	400	266	135	100
125		63		500	280	175	183
126-127		100-160		500	291	175	223
128		250		600	321	215	345
131-132-133-134	150	10-16-25-40	65	480	295	165	195
135		63		550	350	190	255
136		100		550	355	190	270
137		160		585	355	200	275
138		250		700	405	250	480
151-152-153-154	200	10-16-25-40	80	600	395	200	355
155		63		650	405	215	467
156-157		100-160		680	430	225	550
158		250		830	485	290	920
161-162-163-164	250	10-16-25-40	100	730	475	240	460
165		63		775	520	260	677
166-167		100-160		800	560	270	970
168		250		900	560	310	1470
171-172-173-174	300	10-16-25-40	125	850	530	280	1020
175		63		900	550	300	930
176-177		100-160		1050	650	360	1600
178		250		1200	720	420	2100

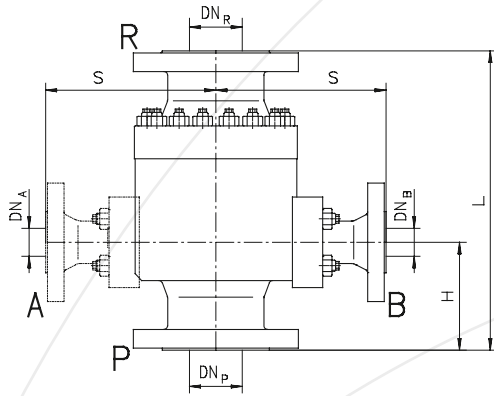

P = Pump outlet
 R = Pipeline/ process
 B = Bypass connection
 (A = Start-up connection as option)

ASME

Size	DN _R /DN _P	PN	DN _B	L (mm)	S (mm)	H (mm)	Weight (kg)
073	1½"	150	1"	200	155	75	19
075		300		260	190	90	34
076		600		260	190	90	34
077		900		300	200	110	34
078		1500		310	215	120	47
083	2"	150	1"	230	163	90	26
085		300		300	185	115	40
086		600		300	193	110	56
087		900		340	203	130	56
088		1500		350	233	130	85
093	2½"	150	1½"	290	174	110	37
095		300		340	199	125	56
096		600		340	220	125	83
097		900		380	230	140	83
098		1500		400	250	145	89
103	3"	150	1½"	310	191	115	48
105		300		380	220	140	69
106		600		380	240	140	85
107		900		410	250	150	85
108		1500		450	275	156	125
113	4"	150	2"	350	211	125	72
115		300		430	240	155	105
116		600		430	266	155	150
117		900		450	280	160	150
118		1500		520	300	190	200
123	5"	150	2"	400	266	135	100
125		300		500	290	175	183
126		600		500	300	175	223
127		900		525	310	185	223
128		1500		650	341	235	345
133	6"	150	2½"	480	295	165	195
135		300		550	350	190	255
136		600		550	355	190	270
137		900		585	355	200	275
138		1500		700	405	250	480
153	8"	150	3"	600	395	200	355
155		300		650	405	215	467
156		600		680	430	225	550
157		900		700	430	225	550
158		1500		880	485	310	920
163	10"	150	4"	730	475	240	460
156		300		775	520	260	677
166		600		800	560	270	970
167		900		800	560	270	970
168		1500		980	570	340	1470
173	12"	150	5"	850	530	280	1020
175		300		900	550	300	930
176		600		1050	650	360	1600
177		900		1050	650	360	1600
178		1500		1250	720	440	2100

SCHROEDAHL

we protect your business

SCHROEDAHL-ARAPP

Spezialarmaturen GmbH & Co. KG

Schoenenbacher Str. 4
51580 Reichshof-Mittelagger
Germany

Phone +49 2265 9927-0

Fax +49 2265 9927-927

www.schroedahl.com

info@schroedahl.com

Schroedahl International Corporation

2400 Augusta Dr. Suite 285

Houston, Texas 77057

United States of America

Phone +1 713 9758351

Fax +1 713 7800421

sic@schroedahl.com