



## Reverse buckling bursting discs, Type U

### Benefits

- Individual product specification for material, pressure and dimension
- Suitable for medium and high pressure
- High corrosion and temperature stability as well as resistance to alternating pressure loads
- Fully vacuum resistant and gas-tight due to solid-metal construction
- Lowest leakage rates
- With integrated burst detection available

### Note

For reverse buckling bursting discs, a holder is required.

### Description

Reverse buckling bursting discs are scored, full metal components of nickel, nickel-based materials (Inconel, Hastelloy)\* or stainless steel. They are mainly used in processes with medium and high pressures, high operating temperatures and considerable pressure fluctuations.

The scoring is located on the atmosphere side of the reverse buckling bursting disc, while the process facing side has a smooth finish so that adherence of the medium is prevented.

The reverse buckling bursting disc type U ensures an immediate, complete opening cross-section whenever the pressure exceeds the permissible range during the process.

\*Inconel and Hastelloy are registered trade names

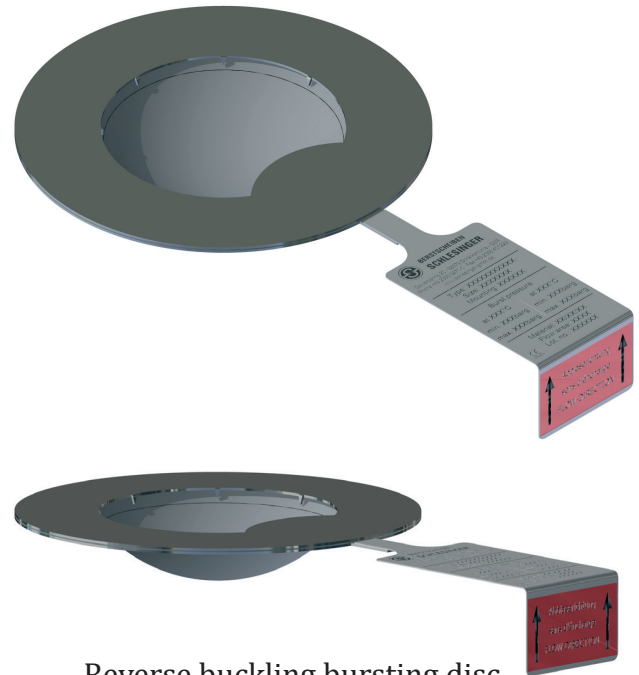

Reverse buckling bursting disc,  
Type U (circular-scored)

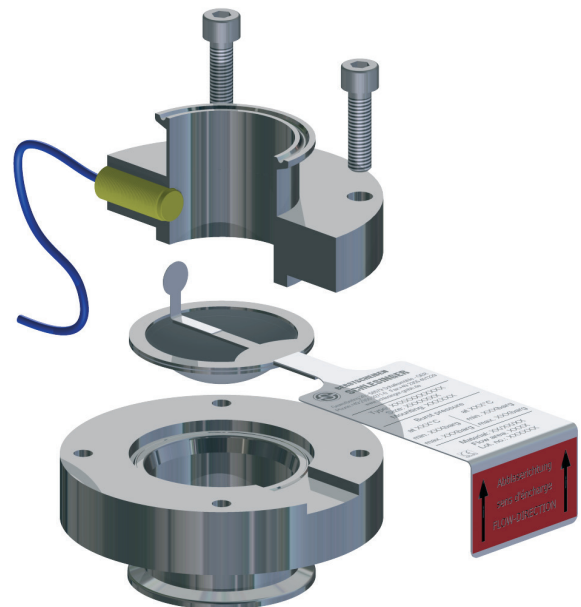

Reverse buckling bursting disc  
with inductive proximity switch  
in bursting disc holder Type BHS



## Installation

Our reverse buckling bursting discs are mounted in the holder directly between standard flanges according to EN1092 or ASME B16.5. Furthermore they can be used within the BHS bursting disc holder type of Berstscheiben Schlesinger GmbH. Reverse buckling bursting discs are used for their excellent properties for example in reactors, pressure vessels and gas cylinders either as sole pressure protection or in combination with a safety valve.

## Function

For releasing the pressure during the process from the permissible area, use the U type reverse buckling bursting disc.

The principle of the Euler buckling pin is used: reverse buckling bursting discs are domed opposite to the pressure direction. Upon reaching the burst pressure the dome reverses and ruptures along the scoring.

## Technical data

### General remarks

Configuration	full metal, laser scored, domed to the medium
Media	gas, steam, liquid (gas cushion is required)
Temperature range	-196°C to +550°C
Tolerance of Burst pressure	±10% (±5% on request)

### Materials

Stainless steel	standard application
Nickel	for lowest pressures
Inconel	for high temperatures
Hastelloy	esp. corrosion resistant
Tantal	extremely resistant to corrosion

\*Special materials on request



## Technical data

### Sealing materials

PTFE	standard seal
Klingsil* C4400	for high temperatures
Graphite	for very high temperatures

\* Klingsil is a registered trademark.

### Dimensions

DN	15 to 400
Inch	1/2" to 16"

### Certifications

ATEX approval
CE marking according to Directive 2014/68 EU
QM-system according to ISO 9001:2015

### Minimum burst pressures in barü at 20 °C

### Free cross-section [mm<sup>2</sup>]

DN	Nickel	Stainless steel/ Hastelloy/ Inconel	minimum
15	5	10	
20	4,5	8	215
25	3	6	385
32	2,5	3,5	650
40	2,5	3	900
50	1	2,5	1450
65	1	2	2400
80	1	2	3900
100	1	2	6350
125	1	2	
150	1	1	10.500
200	1	1	15.500
250	1	1	27.000
300	1	1	
350	1	1	
400	1	1	

\*For materials not listed, please enquire.