



Bursting caps and plates

Benefits

- Individual product specification for material, pressure and dimension
- High level of leak-tightness
- Cost-efficient production in large volumes
- Simple installation

Description

Bursting caps and plates are single-layered bursting discs made of nickel, nickel-based materials (Monel, Inconel, Hastelloy)* or stainless steel with a particularly high level of leak-tightness.

We mark each bursting cap and bursting plate with the appropriate response pressure and the year of production as well as the batch number, as required. Thus we prevent a potential product mix-up.

*Monel, Inconel and Hastelloy are registered trade names

Installation

Bursting caps and plates are mounted in screw couplings. They are clamped with a pressure fitting (e.g. a screw). We require the exact measurements of the pressure fitting before production starts to ensure optimal bursting behaviour. Alternatively, the pressure parts should be produced according to our specifications.

Easy installation is another advantage. Unintentional installation of several overlapping parts, in particular for bursting caps, is prevented, so that the bursting caps tear reliably at the bursting pressure specified. We can produce bursting plates at a good price and with consistently high quality, particularly in large volumes.

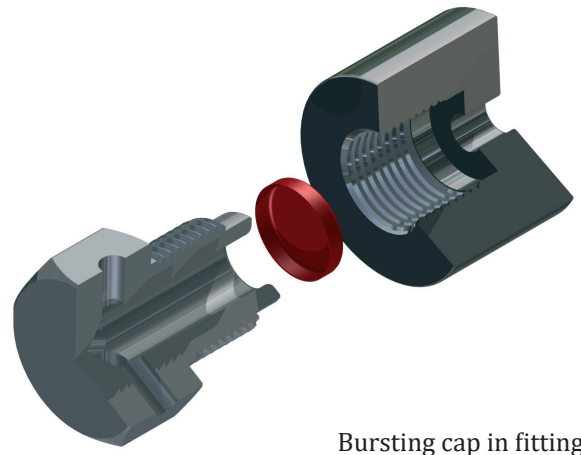

Bursting cap in fitting

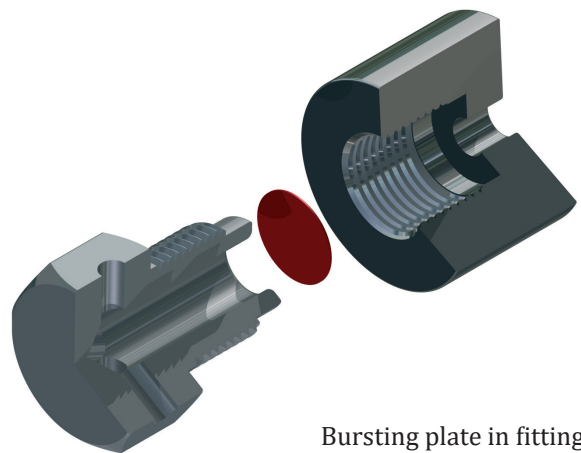

Bursting plate in fitting

Function

Millions of our bursting caps and plates are used to safeguard pressure in CO₂ cartridges. These cartridges are in turn used to ensure pressure, for example in fire extinguishers. Our bursting caps and plates fulfil three important functions in this case:

1. Preventing unintentional release of the gas, which would render the fire extinguisher unusable
2. Bursting reliably and without delay when needed, so that the fire extinguisher is immediately ready for operation.
3. Preventing a possible explosion of the container due to excessive overpressure, e.g. caused by high temperatures in a fire.



Technical data

General remarks

Media	gas, steam, liquid
Temperature range	-80°C to 450°C
Tolerance of Burst pressure	± 10 % (± 5 % on request)

Burst pressure [bar]

Material*	Min.	Max.
Inconel	75	500
Nickel	75	500
Stainless steel	130	800
Hastelloy	130	800

* Special materials like Tantalum, Monel or Titan on request.

Materials*

Nickel, Stainless steel	standard application
Inconel	for high temperatures
Hastelloy	esp. corrosion resistant

* Special materials like Tantalum, Monel or Titan on request.

Certifications

ATEX approval
CE marking according to Directive 2014/68 EU
QM-system according to ISO 9001:2015

Standard nominal size*

Outside Ø [mm]	7	8,5	10	11	12,5	13,9	18	20	24	30
----------------	---	-----	----	----	------	------	----	----	----	----

*Special size on request.

Standard thread*

Metrical threads	M 8	M10	M12		
BSP	G 1/4"	G 3/8"	G 1/2"	G 3/4"	G 1"
UNF	7/16" - 20 UNF	1/2" - 20 UNF			

*Special size on request.