

**Bi-directional in-line detonation flame arrester**

**KITO® EFA-Det4-IIB3-.../...-1.2**

**KITO® EFA-Det4-IIB3-.../...-1.2-T (-TT)**

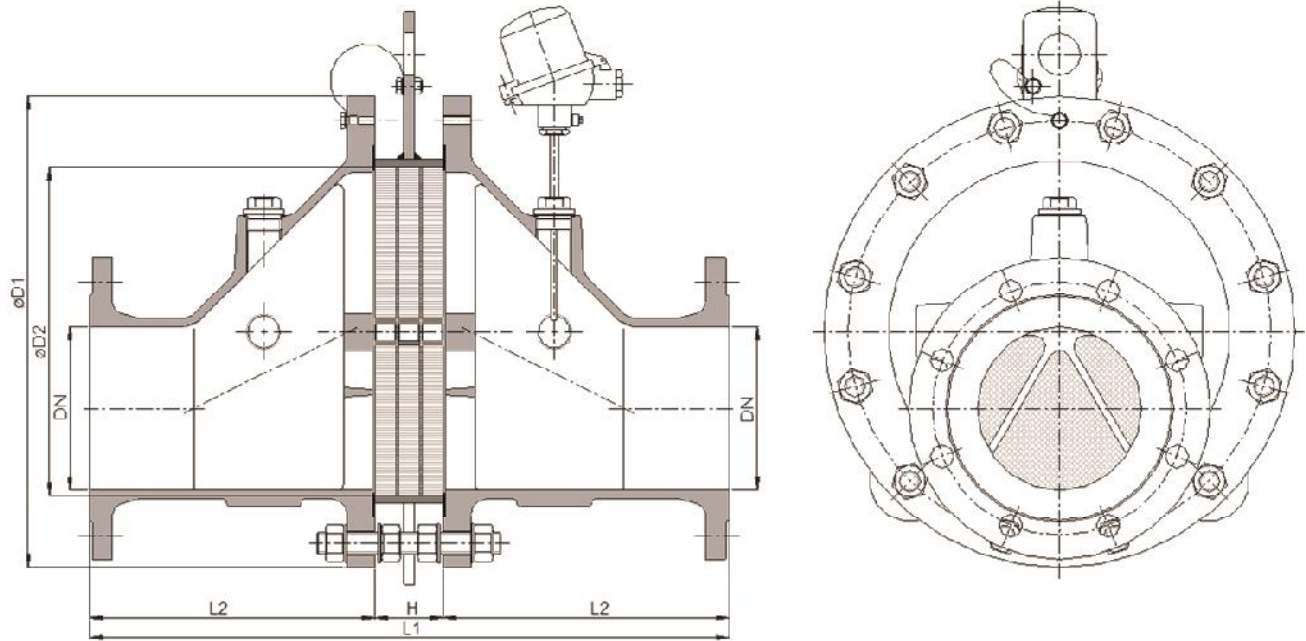
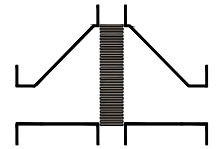

Type examination certificate to DIN EN ISO 16852 and C E -designation in accordance to ATEX-Guideline 94/9/EC

NG	DN	ANSI	D1	D2	L1	H	L2	kg*
65	25 PN 40	1"	155	70	304	64	120	12
	32 PN 40	1 ¼"						
100	40 PN 40	1 ½"	220	106	354	64	145	26
	50 PN 16	2"						26
150	50 PN 16	2"	285	159	414	64	175	43
	65 PN 16	2 ½"						44
	80 PN 16	3"						46
200	80 PN 16	3"	340	206	464	64	200	64
	100 PN 16	4"						65
	100 PN 16	4"						119
300	125 PN 16	5"	445	308	626	86	270	122
	150 PN 16	6"						122
	150 PN 16	6"						186
400	200 PN 10	8"	565	388	716	86	315	206
	200 PN 10	8"						292
500	250 PN 10	10"	670	485	846	86	380	302
	250 PN 10	10"						430
600	300 PN 10	12"	780	584	986	86	450	446
	300 PN 10	12"						
800	350 PN 10	14"	1015	810	1350	110	620	
	400 PN 10	16"						

Dimensions in mm

\* weight refers to the standard design

Design subject to change

performance curves: G 0.24 N

Standard design

- housing : cast steel 1.0619, stainless cast steel 1.4408
- gasket : HD 3822, PTFE
- KITO® flame arrester element : completely interchangeable
- KITO® casing : steel (galvanized to NG 400), stainless steel mat. no. 1.4571, 1.4581
- KITO® grid : stainless steel mat. no. 1.4310, 1.4571,
- bolts/nuts : galvanized steel, SS
- temperature sensor : PT 100 (option); connection 3/8"
- flange connection : DIN EN 1092-1 form B1, ANSI 150 lbs. RF

Application

For installation into pipes to the protection of vessels and components against **stable** detonation of flammable liquids and gases. Tested and approved as detonation flame arrester **type 4**. Approved for all substances of explosion groups IIA1 to IIB3 with a maximum experimental safe gap (MESG) ≥ 0.65 mm. Bi-directionally working in pipes, whereby an operating pressure of 1.2 bar abs. and an operating temperature of 60°C must not be exceeded. The installation of the detonation flame arrester into horizontal and vertical pipes is permissible. Provided with one or two temperature sensors (PT 100) the armature is certified against short time burning from one or both sides. If only one thermal sensor is attached, it must be installed into that part of the body from which a fire is expected.



Example to order:

**KITO® EFA-Det4-IIB3-100/40-1.2-T**  
(design with thermo couple element)

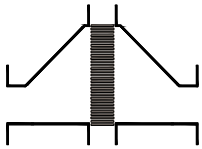

**Bi-directional in-line detonation flame arrester**  
**KITO® EFA-Det4-IIB3-.../...-1.2**  
**KITO® EFA-Det4-IIB3-.../...-1.2-T (-TT)**  
**G 24 N**

The flow capacity  $\dot{V}$  refers to a density of air with  $\rho = 1.29 \text{ kg/m}^3$  at  $T = 273 \text{ K}$  and a pressure of  $p = 1.013 \text{ mbar}$ .  
 The flow capacity for gases with different densities can be calculated sufficiently accurate by the following approximation equation:

$$\dot{V} = \dot{V}_b \cdot \sqrt{\frac{\rho_b}{1.29}} \quad \text{or} \quad \dot{V}_b = \dot{V} \cdot \sqrt{\frac{1.29}{\rho_b}}$$

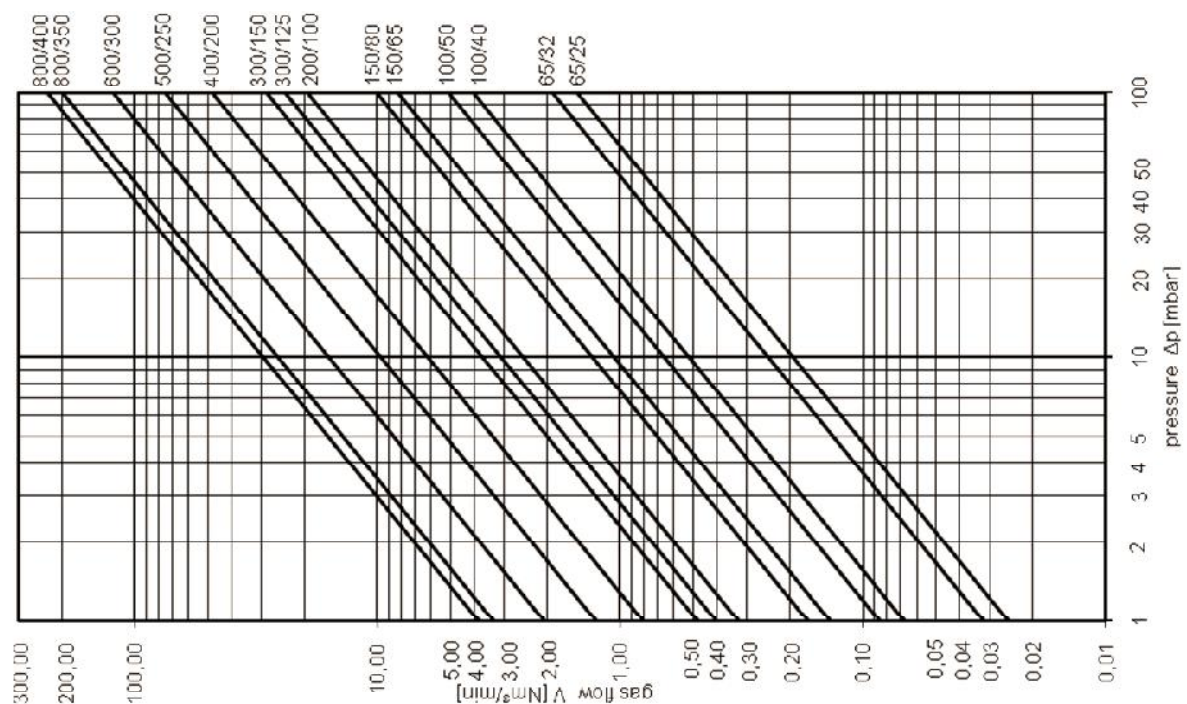
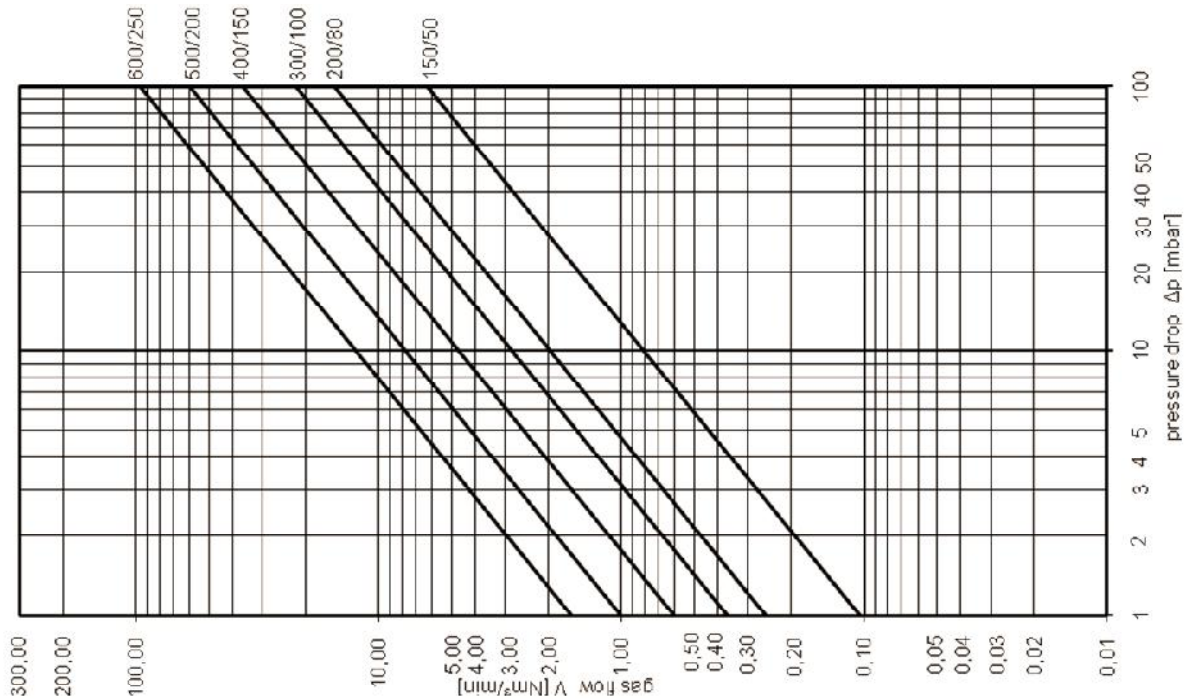

Design subject to change